

paradisoterrestre



Since the beginning, the human being has contributed with his handcrafts to build up his own heaven on earth. The sign of mankind marks every possible heaven on earth.

Dino Gavina

Bologna, late Forties. In the shop of a young upholsterer one of the most significant revolutions in the field of twentieth-century design and art is about to take place. A human adventure, even before being an entrepreneurial one, destined to unfold for more than half a century and to trigger a radical transformation in Italian and international design. The protagonist of this intense and fruitful creative season is Dino Gavina, a multifaceted and subversive figure, a man impossible to circumscribe in conventional definitions.

The undisputed merit of the Bolognese entrepreneur was his ability to surround himself with some of the most prestigious figures in the world of art and architecture. Among the most important names Carlo Scarpa, Achille and Pier Giacomo Castiglioni, Ignazio Gardella, Kazuhide Takahama, Marcel Breuer, Man Ray, Marcel Duchamp, Lucio Fontana, Roberto Matta, Tobia Scarpa, Luigi Caccia Dominioni, Enzo Mari,...

Paradisoterrestre was Gavina's last major enterprise, conceived in the late Seventies and inaugurated in 1983. The brand is initially specialized in the creation of outdoor objects and urban furniture. The wealth of knowledge, experience and frequentation, consolidated over the previous years, is poured into Paradisoterrestre. The house, in its components, the artificial one of the building and the natural one of the garden, is the space of life. Gavina's will is to transform it into that small, personal, intimate corner of Heaven on earth. An Eden lost and rediscovered thanks to the beauty of things, where functionality of the objects proposed in the catalogue matches the contemplation of forms.

Paradisoterrestre universe, made up of solid and synergetic relationships based on friendship and esteem, has been and continues to be a hotbed of culture in which some of the most famous pieces of Italian design are conceived. Since 2017 cultural and material heritage merges with innovation: the original project is realized not only through the re-edition of historical pieces designed by great masters, but also by encouraging and promoting the production of new collections in collaboration with big names on the contemporary scene.

In the new course Paradisoterrestre presents its catalogue – ranging from historical to contemporary Editions – which has as its own characteristics the cornerstones of Dino Gavina's visionary and anticipatory experience: dialogue between art and design; excellence of the production quality; artisan tradition applied on an industrial scale; language and aesthetic experimentation.

In 2018 Paradisoterrestre opened the doors of its new home in Bologna at Via De' Musei 4. A hybrid space between a gallery and a showroom, between art and design. Creative director Pierre Gonalons conceived the interior design as the home of an ideal collector, inspired by the Italian style of the Seventies. The internal architecture of the enchanting first floor apartment respects the history of the building, located in the central area of the Quadrilatero a few steps from Piazza Maggiore, while suggesting a contemporary living space.

A house inhabited by objects, Editions from Paradisoterrestre catalogue and important pieces from the Historical Design Selection, for a total experience of the Paradisoterrestre universe between art, architecture and collectible design. Major exhibitions have been held at the gallery: ULTRAMATTA - Roberto Matta's amazing adventure in the world of design (2019), TOBIA SCARPA - Dall'arte della misura silenziosamente (2020), Paola Pivi - Rock the art (2021), Augusto Betti - Trasversale • Pulsazione • Ritmo (2022) and Cento % Dino (2022).

ALLEN JONES

(1937)

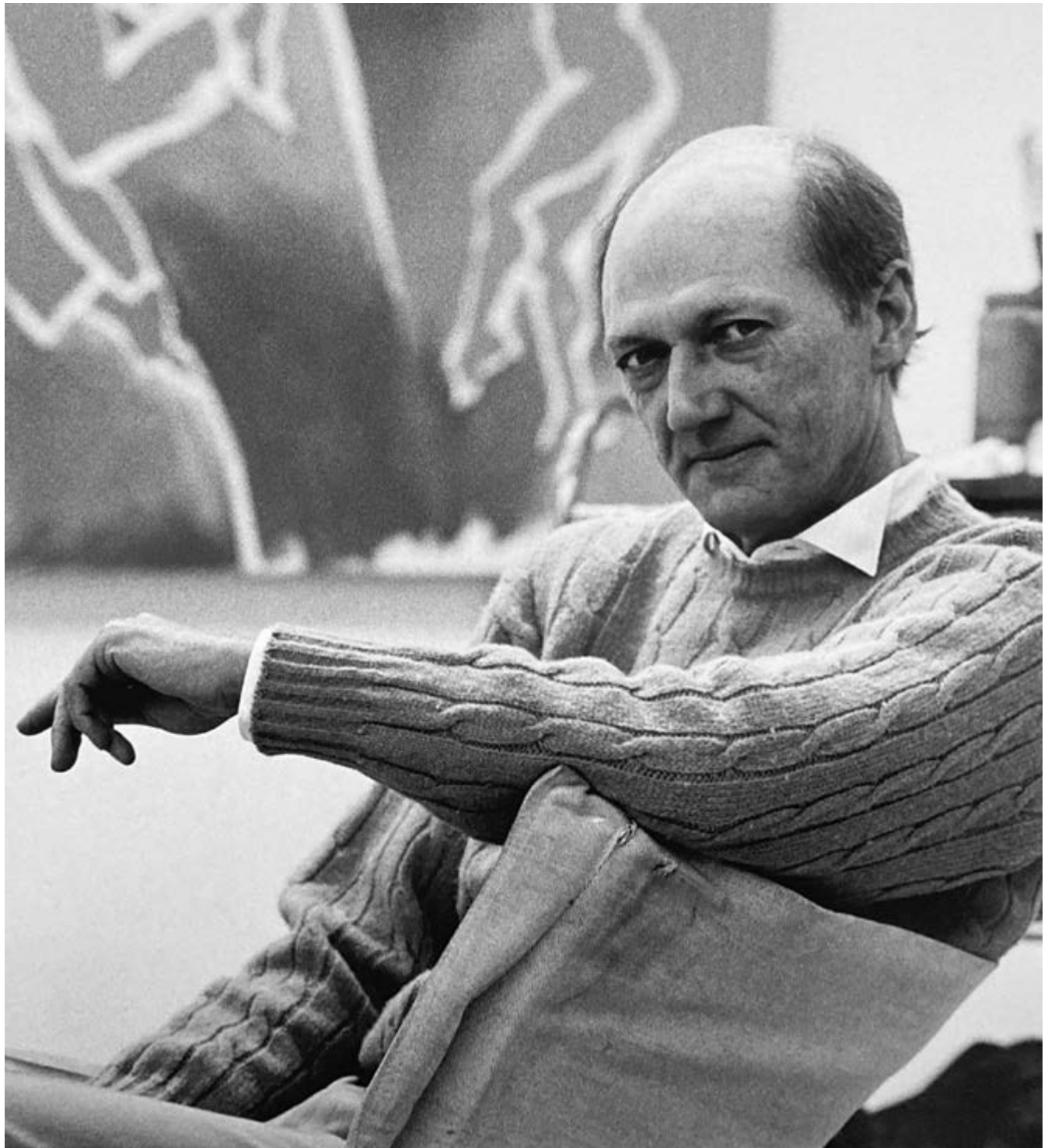

The legendary British pop artist met Dino Gavina in the 1970s. Several were the projects and proposals that the artist sent to his entrepreneur friend, mostly remained at the prototype level.

Allen Jones is one of Britain's most distinguished artists from the pioneering Pop Movement, with paintings and sculptures in many important international collections, including Tate Gallery and the Victoria & Albert Museum in London, the Museum of Modern Art in New York, the Musée d'Art Moderne, Paris, the Hirshhorn Museum and Sculpture Garden in Washington DC, the Museum of 20th-Century Art in Vienna, the Wallraf-Richartz Museum in Cologne, the Moderna Museet in Stockholm and the Stedelijk Museum in Amsterdam.

He represented the UK at the Paris Biennale in 1963, where he received the Prix des Jeunes Artistes. In 1978 – 79 there was a painting and sculpture retrospective of his work at the Walker Art Gallery, Liverpool and the Serpentine Gallery, London and in 1995 there was a retrospective exhibition of his complete graphic works at the Barbican Art Gallery in London, which for three years toured the world under the auspices of the British Council.

In 2007-8 solo exhibitions of his work were exhibited simultaneously at Tate Britain and The Royal Academy of Arts. To mark his 75th birthday in 2012 a large, retrospective exhibition, "Off the Wall", exhibiting sculptures, paintings, prints and drawings from the past 55 years of his career, toured through Europe, with further venues in South America through 2015. A Royal Academy of Arts retrospective 2014-2015 presented his work on thematic lines.

Commissions have included large scale mural projects for Fogal in Basel and Zurich, and two major London restaurants; monumental steel sculptures for London Bridge City, the Chelsea and Westminster Hospital, London, Taikoo Place in Hong Kong and Glaxo SmithKline world headquarters, London. In 2006 he installed 10 meters high sculpture commissions for the Yuzi Paradise Sculpture parks in both Shanghai and Guilin, China. Two large works have been acquired by the city of St Louis, USA and the Barada Foundation in Lisbon. In 2019 a monumental painted steel sculpture was erected on the Greenwich Peninsula development.

In 2008 a large-scale, 5-piece sculpture was commissioned and installed at Chatsworth in Derbyshire, and a suspended piece has been installed at the headquarters of Allen & Overy in Spitalfields in a Foster & Partners-designed building. Additionally, he has undertaken many private sculpture commissions in the UK and the USA.

He has designed for the Royal Ballet and the Ballet Rambert in England, and for West Deutsche Television in Cologne and Thames Television in the UK. He has designed and had published three books, and a further seven monographs have been published about his work.

Allen Jones was elected a Royal Academician in 1986, and was a Trustee of the British Museum from 1990 to 1999. In 2007 he was awarded an Honorary Doctorate of Arts at Southampton Solent University.

In the 1970s Allen Jones met the Bolognese entrepreneur Dino Gavina and between the two began a deep relationship of friendship. Several were the projects and proposals that the artist sent to his friend, mostly remained at the prototype level. In the new course of Paradisoterrestre the collaboration with Allen Jones finally takes shape in Shoe screen (2022).

SHOE SCREEN

ALLEN JONES

2022



SHOE SCREEN

Designer:
Allen Jones

Materials:
multilayer lacquered wood
with silk-screen printing,
rubber

Paradisoterrestre Edition
2022

W 225 | D 2 | H 220 cm
W 88,5 | D 0,7 | H 86,5 in

A brand new screen by Allen Jones exclusively for Paradisoterrestre in a limited edition of 30 signed and numbered pieces (+2AP).

The legendary British pop artist – part of whose work evolves around the female figure – conceives this piece of furniture as a canvas, enriching it with suggestions drawing on the imagery of fetishism. The screen encompasses the drawing, reproduced in silk-screen printing, of a décolleté surrounded by a cloud, an actualization of a lithograph part of the Shoe Box collection created by Jones himself in 1968.

The screen structure was designed by Japanese architect Kazuhide Takahama for Dino Gavina in the 1970s: five wooden panels joined by a patented rubber hinge system.

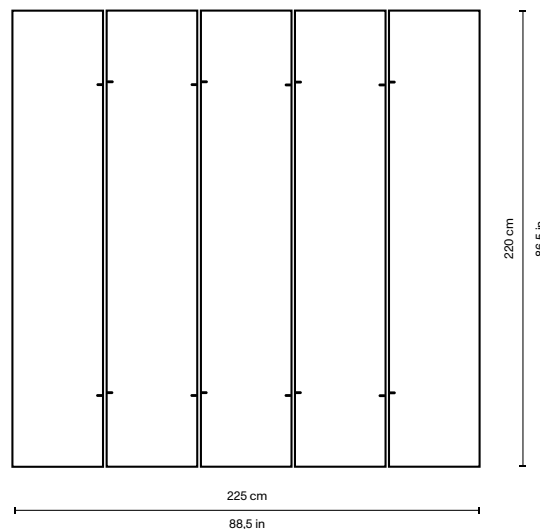

AUGUSTO BETTI

(1919 – 2013)

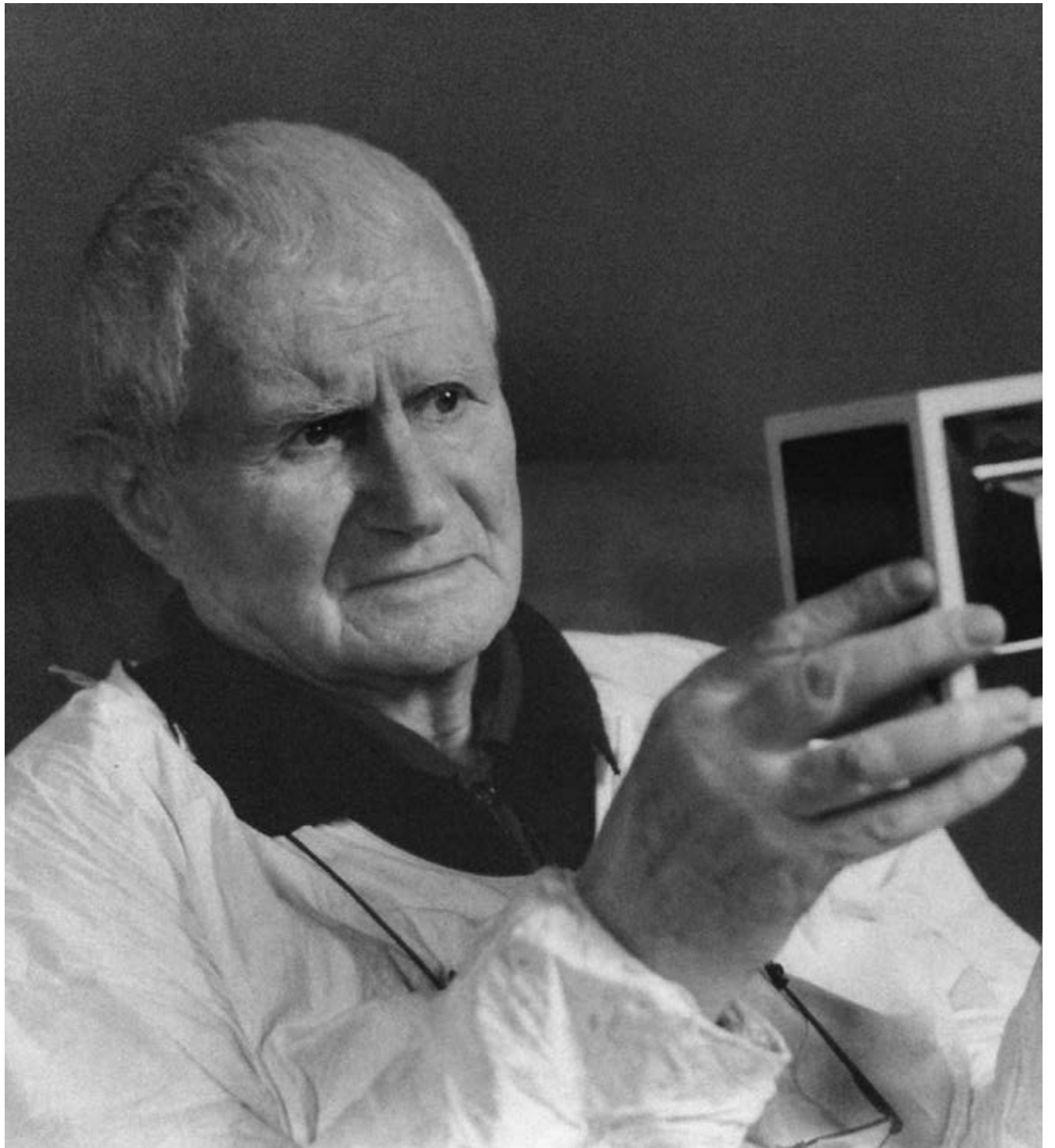

Italian artist whose extraordinary research deserves a (re)discovery. For Augusto Betti, art was a philosophical and spiritual journey, which led him to a very profound understanding of the mysteries of life and of the world.

Augusto Betti became an orphan at the age of nine. The eldest of his siblings, he worked in the Focaccia and Melandri ceramic workshop. He could not pursue the art studies he loved but managed to attend evening classes at the local Municipal School of Drawing. In 1935 he enrolled in the mechanical construction course at the Aeronautical Institute in Forlì. During World War II, he was a mechanical engineer with Primo Stormo da Caccia in Udine, with missions in North Africa, Greece, Algeria. At the end of the war, he began to paint: his first painting was *Il ritratto di Jole* (1945), the portrait of his young wife.

In 1946 he held his first solo painting exhibition at the Gamberini gallery in Forlì. In 1947 he was admitted to the Academy of Fine Arts in Bologna, where his teachers were Giorgio Morandi and Giovanni Romagnoli. Here he deepened his fresco technique. At the same time, he worked in Decio Podio's painting restoration workshop, where he acquired a remarkable sensitivity and mastery of color.

He participated in a series of figurative painting exhibitions. Despite his success, also commercial, in 1955 he opened a laundry-business with his wife to be free to devote himself to experimentation in the artistic field. He named his first abstract artworks "cassette (boxes)", because they were made from square wooden boxes, about a meter wide and a dozen centimeters deep, closed by transparent material, in which he inserted elements that created changing plays of light and movement depending on the point of view. He also began to experiment with the countless possibilities of new synthetic materials. In the same years he created the "semisfere (half-spheres)", made using the bottom of demijohns as a mold, which were hung and projected colored moving images on the walls.

His work met the interests of Silvio Ceccato, director of Centro di Cibernetica e di Attività Linguistiche of the University of Milan, with whom he collaborated for several years. He also collaborated for a very long period with Centro Pio Manzù in Rimini, contributing, among other things, to the organization of the Convegni Internazionali Artisti Critici e Studiosi d'Arte, at which he met the major artists and art critics of the time, several of whom became his friends.

In 1963 a solo exhibition was held at Palazzo del Turismo in Riccione as part of the events of the XII Convegno Internazionale Artisti Critici e Studiosi d'Arte. From 1965 to 1984 he taught Professional Drawing at the Art Institute of Faenza. Particularly interested in the processes by which creativity develops, which he believed to be inherent in every human being from childhood, he carried out in-depth personal studies in this field.

He then devoted himself to design, and with Habitat Sintoni of

Faenza, he realized: the Noodle armchair, the Parete luce floor lamp, the Foemina and Austere table and chair, and the Glass coffee table (1967); the Flou sofa and armchair and the Oscillante armchair (1968), the Prisma sofa and armchair (1971), and the Ciclope chair (1972).

In 1967 he participated with *Orgonoscopio* at VI Biennale d'arte Repubblica di San Marino - Nuove tecniche d'Immagine, chaired by Giulio Carlo Argan, Palma Bucarelli, Umbrò Apollonio, Gian Alberto dall'Acqua. In 1968 he participated in the group show *Achromes* in Milan alongside Agostino Bonalumi, Enrico Castellani, Gianni Colombo, Lucio Fontana, Piero Manzoni and others.

From 1980 to 1986 he assumed the chair of Theory of Perception at the Istituto Industrie Artistiche in Faenza. His hometown Faenza dedicated to him in 2001 the exhibition *Forme della vita* at Palazzo delle Esposizioni and in 2006 the exhibition at Galleria della Molinella. His solo exhibition *Riflessi* promoted by the Municipality of Palazzuolo sul Senio dates back to 2003.

Since 2022 *Paradisoterrestre* has embarked on a journey to rediscover and enhance the work of Augusto Betti with the exhibitions *Augusto Betti – Trasversale • Pulsazione • Ritmo* at *Paradisoterrestre* gallery in Bologna and *Augusto Betti. Artista e designer* at *Fondazione Sozzani* in Milan; by including in its catalogue the re-editions of his design pieces such as *Noodle armchair*, the tea set designed in 1975, *Prisma armchair* and *sofa*, *Glass coffee table* and acquiring the complete archive from his heirs.

NOODLE

AUGUSTO BETTI

1967



NOODLE

Designer:
Augusto Betti

Paradisoterrestre Edition
2022

First production:
Habitat Sintoni, 1967

Materials:
shaped polyurethane, metal
and plywood. Upholstery
available in different fabrics

W 74 | D 60 | H 68 cm
W 29 | D 23,6 | H 26,7 in

The balanced gesture of the hand translates into a volumetric element. The Noodle armchair welcomes us in a harmonic dimension.

To explain to his students the importance of free gestures in the generation of ideas, Augusto Betti takes one of his signs and gives it three-dimensionality, transforming it into an armchair. Homemade tagliatelle lover, he sees the same shape in his creation and so he names it Noodle, underlining also in the choice of the title the importance of leaving space to intuitions.

A simple and essential – yet very original – curved armchair, a clear correspondence to Betti's artistic experiences on the theme of pulsation.

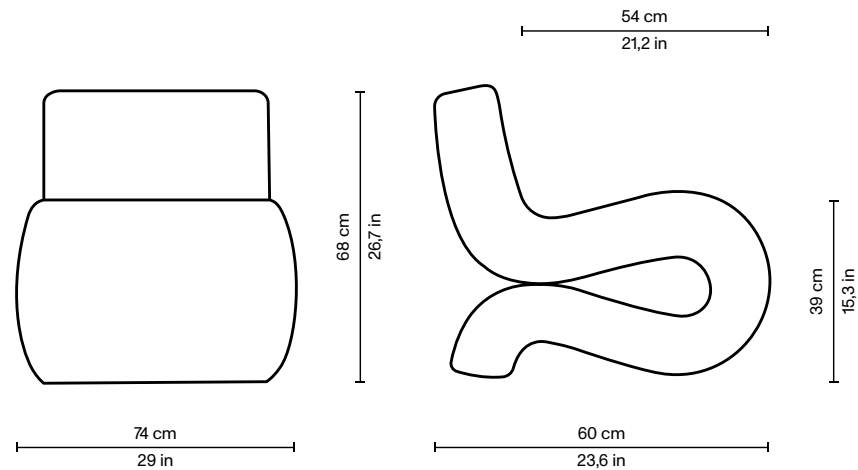

TEA SET 75

AUGUSTO BETTI

1975



TEA SET 75

Designer:
Augusto Betti

Materials:
enamled pottery

Paradisoterrestre Edition
2023

Colours:
pink, mint green, white

First production:
Centro Pio Manzù, 1975

The tea set designed by Italian artist Augusto Betti in 1975 consists of 1 teapot, 1 sugar bowl, 2 cups and 2 saucers. Re-edited by Paradisoterrestre in a limited edition of 100 pieces for each colour, with numbering and signature on the teapot and Certificate of Authenticity. The three available colours – pink, mint green, white – are those originally chosen by the artist. Also available a set consisting of 1 cup and 1 saucer without numbering.

“I consider the cup of this tea set my most successful design object. A hemisphere of clay was taken at two points in the vertical part below the rim and folded horizontally. A simple intervention of the hand, transversal to the development of the hemisphere, gives rise to the “grips” of the cup. We have a perfect example of how the work of the hands integrates with that of the mind in design, suggesting new solutions and how important it is to let go, not intentionally, but through doing. It is essential for the design of ceramics to have “hands in clay”, to learn to move it by understanding the wonderful possibilities it offers. The clay yields to the movement of the hand suggesting forms that go beyond intentionality. Its language cannot be known except through direct experience.” – Augusto Betti

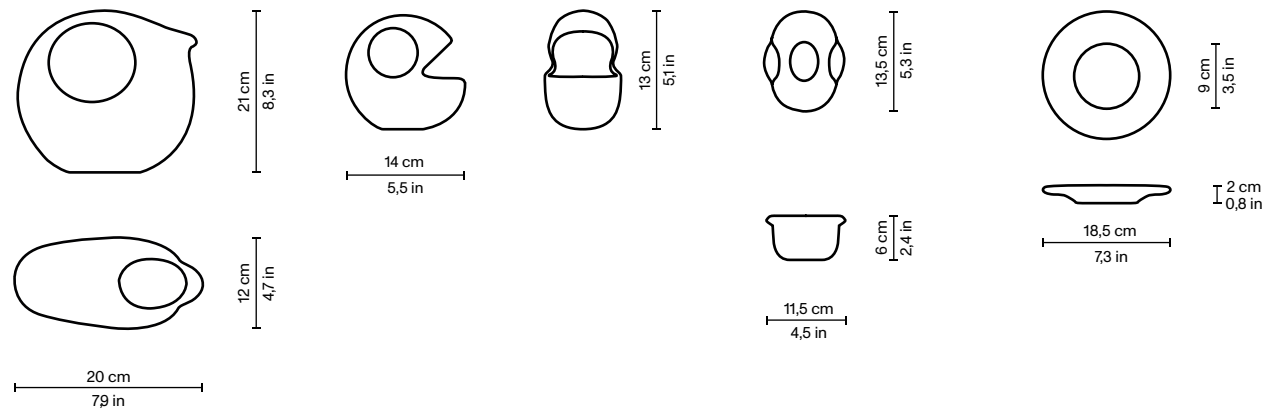

GLASS

AUGUSTO BETTI

1967



GLASS

Designer:
Augusto Betti

Materials:
glass

Paradisoterrestre Edition
2023

Colours:
smoked grey, bronze

First production:
Habitat Sintoni Faenza, 1967

W 40 | D 40 | H 40 cm
W 15,7 | D 15,7 | H 15,7 in

Designed by Augusto Betti in 1967, Glass coffee table consists of a smoked glass element whose cubic conformation allows for different compositional variations.

Paradisoterrestre re-edition of this coffee table is presented for the first time on the occasion of miart and Milan Design Week 2023 at the exhibition AUGUSTO BETTI artista + designer in collaboration with Fondazione Sozzani.

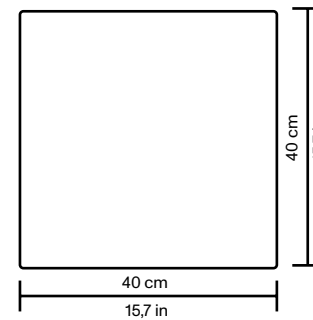
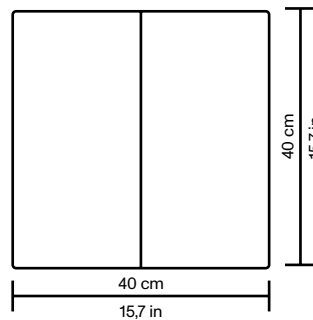

PRISMA

AUGUSTO BETTI

1971



PRISMA ARMCHAIR

Designer:
Augusto Betti

Paradisoterrestre Edition
2023

First production:
Habitat Sintoni Faenza, 1971

Materials:
chrome-plated steel tubular,
wood, polyurethane foam,
upholstery available in diffe-
rent fabrics

W 110 | D 100 | H 80 cm
W 43,3 | D 39,4 | H 31,5 in

Prisma armchair was conceived by Augusto Betti in 1971, during lectures to his students in his hometown Faenza.

The geometric and rigorous shapes of the prism soften up to transform the polygon into an unmistakable '70s style soft and cozy armchair.

Paradisoterrestre re-edition of this armchair is presented for the first time on the occasion of miart and Milan Design Week 2023 at the exhibition AUGUSTO BETTI artista + designer in collaboration with Fondazione Sozzani.

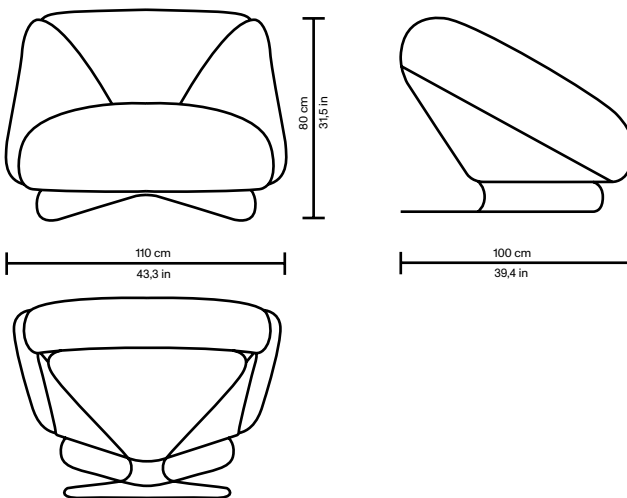

PRISMA SOFA

Designer:
Augusto Betti

Paradisoterrestre Edition
2023

First production:
Habitat Sintoni Faenza, 1971

Materials:
chrome-plated steel tubular,
wood, polyurethane foam,
upholstery available in diffe-
rent fabrics

W 220 | D 100 | H 80 cm
W 86,6 | D 39,4 | H 31,5 in

Prisma sofa was conceived by Augusto Betti in 1971, during lectures to his students in his hometown Faenza.

The geometric and rigorous shapes of the prism soften up to transform the polygon into an unmistakable '70s style soft and cozy sofa.

Paradisoterrestre re-edition of this sofa is presented for the first time on the occasion of miart and Milan Design Week 2023 at the exhibition AUGUSTO BETTI artista + designer in collaboration with Fondazione Sozzani.

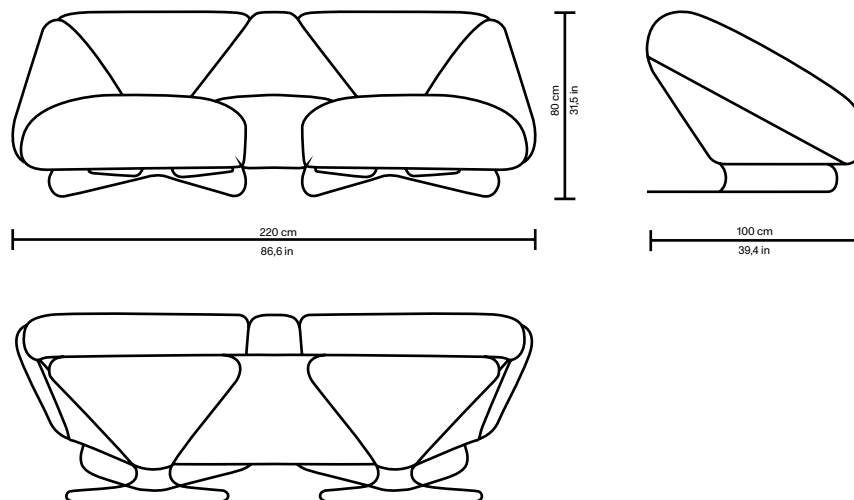

CALORI & MAILLARD

(1986 & 1984)



Artist duo since 2009.
The collaboration between
Letizia Calori and Violette
Maillard combines back-
grounds in architecture and
film studies into a practice
where the real and the
surreal merge.

Letizia Calori (Bologna, 1986) and Violette Maillard (Bourg la Reine, 1984), have been working as artist duo Calori & Maillard since 2009.

Their collaboration combines backgrounds in architecture (Calori) and film studies (Maillard) into a practice that merges the real and the surreal, often bringing the absurd into a real situation. Their research is focused on observing and interpolating the relations between architecture and the human body. They intervene on hierarchies and conventions, overturning them with sudden and unexpected elements, then searching for and finding an exit route with neutralizing irony.

The artists trained at the Stedelschule in Frankfurt am Main with Tobias Rehberger, and at the IUAV in Venice. In 2013 the duo received the Ernst & Young Prize and the Stedelschule Portikus e.V. grant. In 2014 they were artists in residence at Österreichische Skulpturenpark in Graz (Austria), in collaboration with the Joanneum Museum. In 2015 they collaborated with the Heinz and Gisela Friederichs Foundation on the project L'Oiseau de Feu, a ballet of tower cranes. The same year they were selected by the Fundación Botín, Santander as artists in residence. In 2016 they were given the XIII edition New York Prize by the Italian Ministry of Foreign Affairs and the Italian Academy of Advanced Studies at Columbia University, they were also artists in residence at ISCP.

In 2017 the former Gavina showroom in Bologna reopened to the public with the site-specific exhibition Causerie promoted by Istituzione Bologna Musei | MAMbo - Museo d'Arte Moderna di Bologna. In 2018 the duo took part in the European Photography Festival in Reggio Emilia with the project Energia Potenziale. Their research continues by experimenting with different materials and extending the concept of the artwork into transdisciplinary fields such as design, photography, and the mechanical industry. In 2023 their work was acquired by the Museo Fotografia Contemporanea as part of L'Italia è un desiderio promoted by MiC-DGCC, Mufoco and Fondazione Alinari.

Calori & Maillard have taken part in several international shows, in both institutional and experimental spaces such as MAMbo (Bologna), Palazzina dei Bagni Misteriosi (Milan), ISCP, and the Italian Cultural Institute (New York), MMK and Deutsche Film-museum (Frankfurt am Main), Villa Iris – Fundación Botín (Santander), Österreichische Skulpturenpark (Graz), and Moderna Museet (Stockholm).

For Paradisoterrestre Calori & Maillard created some limited edition pieces. In 2017 for the exhibition project Causerie – conversation they presented the Murano glass vase Altabella 23 - Portare acqua al mare, inspired by the Gavina shop designed

by Carlo Scarpa in Bologna, venue of the show. In 2024 for the exhibition WE ARE FOU at Paradisoterrestre Gallery they created Moi, toi et Le Témoin (2024), a Man Ray-inspired intervention on Kazuhide Takahama's iconic Mantilla sofa and Sleeping beauty, a tribute to Meret Oppenheim's renowned Surrealist coffee table.

ALTABELLA 23
“PORTARE
ACQUA AL MARE”

CALORI
& MAILLARD

2017



ALTABELLA 23 “PORTARE ACQUA AL MARE”

Designer:
Calori & Maillard

Materials:
Murano glass, satin finish

Paradisoterrestre Edition 2017 Colours:
emerald green, ochre yellow,
cobalt blue

W 26 | D 14 | H 30 cm
W 10,2 | D 5,5 | H 11,8 in

In January 2017 Calori & Maillard took part to Art City, an event linked to Arte Fiera, with the solo show *Causerie – conversation* supported by Istituzione Bologna Musei | MAMbo – Museo d'Arte Moderna di Bologna in collaboration with Paradisoterrestre. The exhibition took place at Gavina shop located in via Altabella 23 in Bologna designed by Carlo Scarpa.

The work *Altabella 23 – Portare acqua al mare* (Bring water to the sea), a limited edition Murano glass vase designed by female duo exclusively for Paradisoterrestre on the occasion of the exhibition, is a tribute to the Venetian architect and to his project for Gavina. The shape proposes the architectural element with a double circle, recurrent both in the openings of the façade and in the details of one of the columns inside. The available colours – emerald green, ochre yellow, cobalt blue – recall the tones chosen by Scarpa within the space.

Murano glass is the denomination which characterizes the artistic glass manufactured in Italy, that is why these vases tribute to Scarpa are blown specifically by Murano Master Glasblower Simone Cenedese.

Limited edition of 10 for each colour, with engraved identification number and artists' signature.

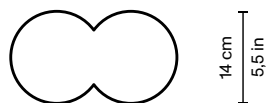
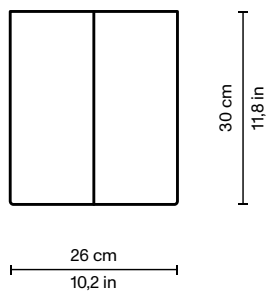

SLEEPING
BEAUTY

CALORI
& MAILLARD

2024



SLEEPING BEAUTY

Designer:
Calori & Maillard

Materials:
bronze, pigments on bronze,
brushed lacquered wood

Paradisoterrestre Edition 2024

W 36 | D 50 | H 74 cm
W 14 | D 16,8 | H 29 in

Calori & Maillard creates exclusively for Paradisoterrestre Sleeping beauty, presented for the first time in the exhibition WE ARE FOU at Paradisoterrestre Gallery.

Sleeping beauty is a tribute to Meret Oppenheim. The artists reinterpret the famous Surrealist coffee table with bird's feet and shape bronze into a bright pink flamingo.

The works are produced in collaboration with Fonderia Battaglia.

Limited edition of 25 + 3AP with engraved identification number and artists' signature.

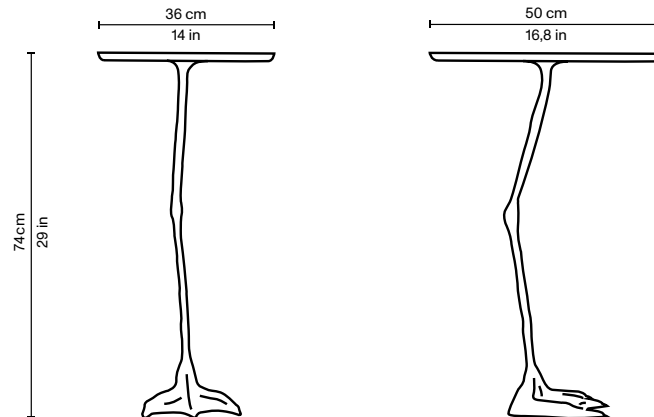

MOI, TOI ET
LE TÉMOIN

CALORI
& MAILLARD

2024



MOI, TOI ET LE TÉMOIN

Designer:
Calori & Maillard / Kazuhide
Takahama

cloth with snaps fitting on
metal rods inserted into the
structure, embroidery

Paradisoterrestre Edition 2024

Colours:
blue, green, white

Materials:
plywood base, polyurethane
foam structure, chenille velvet

W 160 | D 86 | H 70 cm
W 63 | D 33,8 | H 27,5 in

With Moi, Toi et Le Témoin, presented for the first time in the exhibition WE ARE FOU at Paradisoterrestre Gallery, Calori & Maillard intervene on Kazuhide Takahama's iconic sofa Mantilla 160.

Two embroidered eyes, inspired by Man Ray, look out from the elegant mantle that covers the structure and search for the observer.

Limited edition of 9 for each colour (blue, green, white).

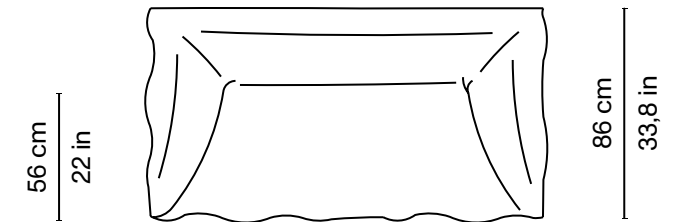
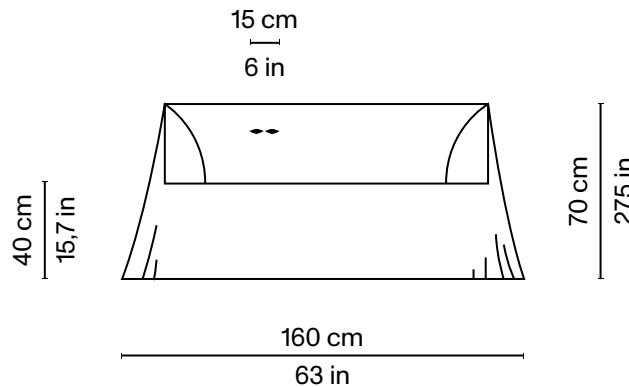
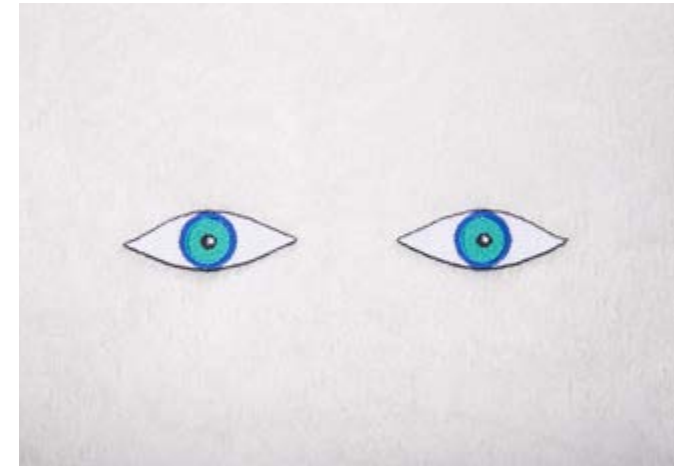

DINO GAVINA

(1922 – 2007)

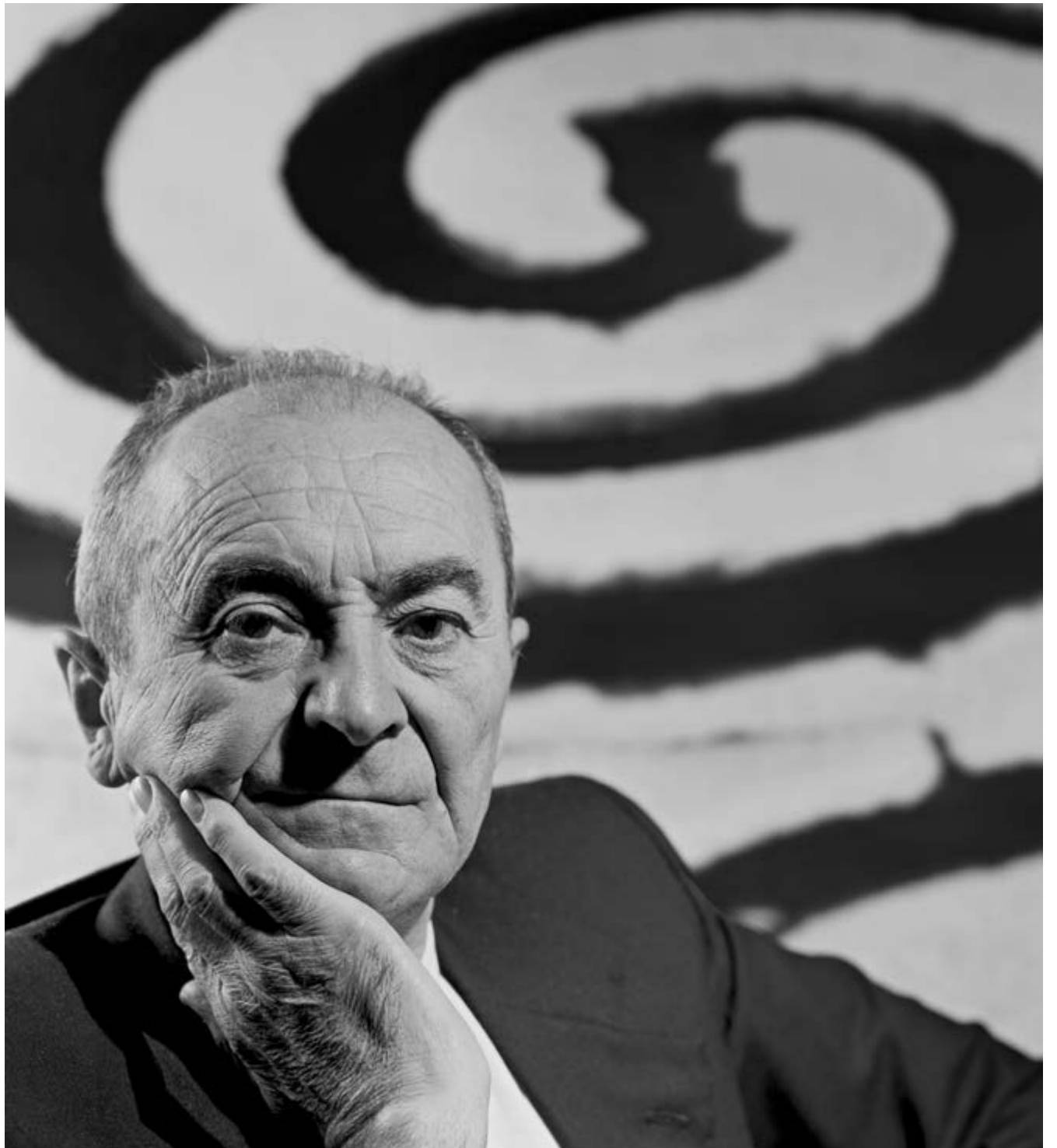

Catalyst for creativity,
eclectic and subversive
Dino Gavina made the
dialogue between design
and art his distinguishing
mark by collaborating with
the most important
designers, architects and
artists of his time.

Dino Gavina's extraordinary adventure started when he opened an upholstery workshop in Bologna located in Via Castiglione, where in the first years after the Second World War – compelled to use salvage materials for military and railway supplies – he started producing and marketing his first furnitures.

Interested and fond in literature, visual arts and theatre; we'd say: "he travelled and met people", but he seizes the genius and the chance to create things and characters: this is Dino Gavina's creative blend. Indefatigable director of people, things, events arising from his imagination, a continuously moving vortex that crowned his whole life. Meetings with personalities, who sometimes he personally created. He stroke up a beautiful friendship with Lucio Fontana. He was in Milan and on the occasion of the 10th Triennale Exhibition he met the Castiglioni brothers; in 1957 at the 11th Triennale he met Kazuhide Takahama, who set up the Japanese pavilion; in Venice he met Carlo Scarpa, who in 1960 became the President of Gavina spa, the company where Tobia's first pieces – Scarpa's son – were then produced...A life punctuated by extraordinary characters.

The Gavina shop designed by Carlo Scarpa in Via Altabella in Bologna, the extraordinary showroom in San Lazzaro di Savena designed by Achille and Pier Giacomo Castiglioni, still admirable modern architectures, were the venues where the memorable evenings of Man Ray and Marcel Duchamp took place. San Lazzaro was the location where in 1967 Centro Duchamp was born, as a tribute to him, where future kinetic artists worked alongside the great masters, an art project made in series for new users.

Long is the list of artists, with whom Dino Gavina collaborated; he dealt with a myriad of worlds, as this is his eclectic side. His companies – Gavina, Flos, Simon, Sirrah, Paradisoterrestre – are well-known: his passion to create furniture and lamps, his indoor and outdoor furniture, his strict line in industrial design, which partly owes to him the opening of new horizons.

– Ilka Alessandra Gavina

LABBRA MIRROR
TRIBUTE TO
MAN RAY

DINO GAVINA

2004



LABBRA MIRROR TRIBUTE TO MAN RAY

Designer:
Dino Gavina

Materials:
silk-screened mirror,
MDF frame

Paradisoterrestre Edition

First production:
Simongavina Paradisoterrestre,
2004

W 170 | D 2,5 | H 68 cm
W 66,9 | D 0,9 | H 26,8 in

Inviting lips radiating sensuality. A prelude to an invitation, a kiss or a smile – whatever you want it to be.

Dino Gavina met Man Ray in Paris. At the beginning the meeting was tense because the artist thought he was facing a journalist or a critic. Then his aggression turned into kindness as soon as he realized that Gavina wanted nothing more than to know him. From the corridor they went to the atelier, and stayed together for hours. At that precise moment an extraordinary lifelong friendship was born.

Labbra mirror tribute to Man Ray was exhibited in the show "Kama – sex and design" at Triennale di Milano in 2012.

Labbra © Man Ray, by SIAE 2021

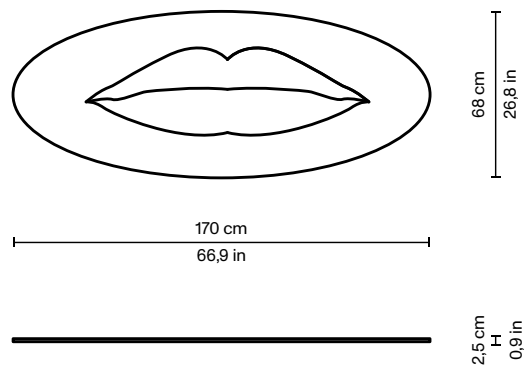
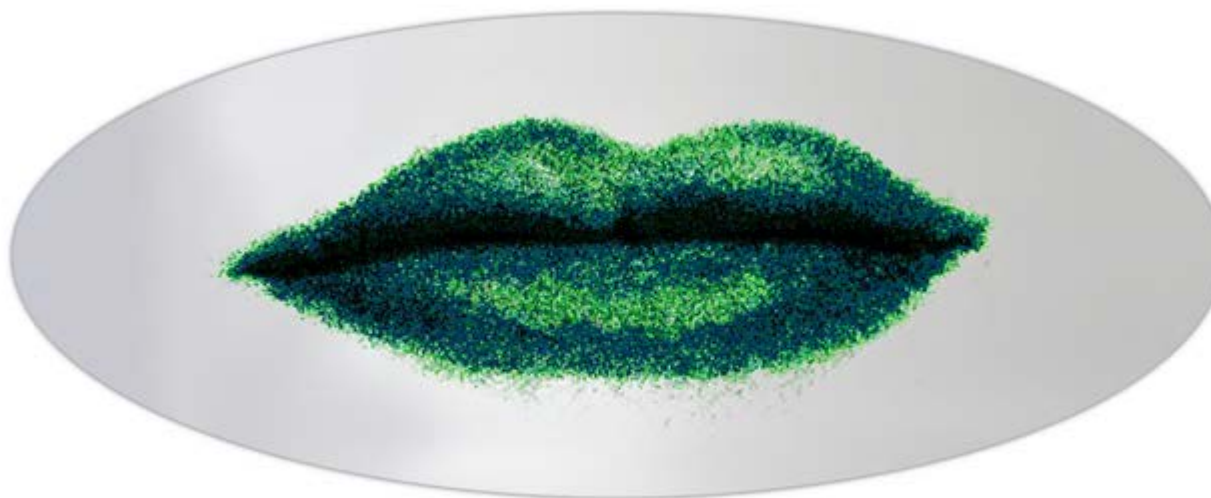

VENERE MIRROR
TRIBUTE TO
MAN RAY

DINO GAVINA

2004

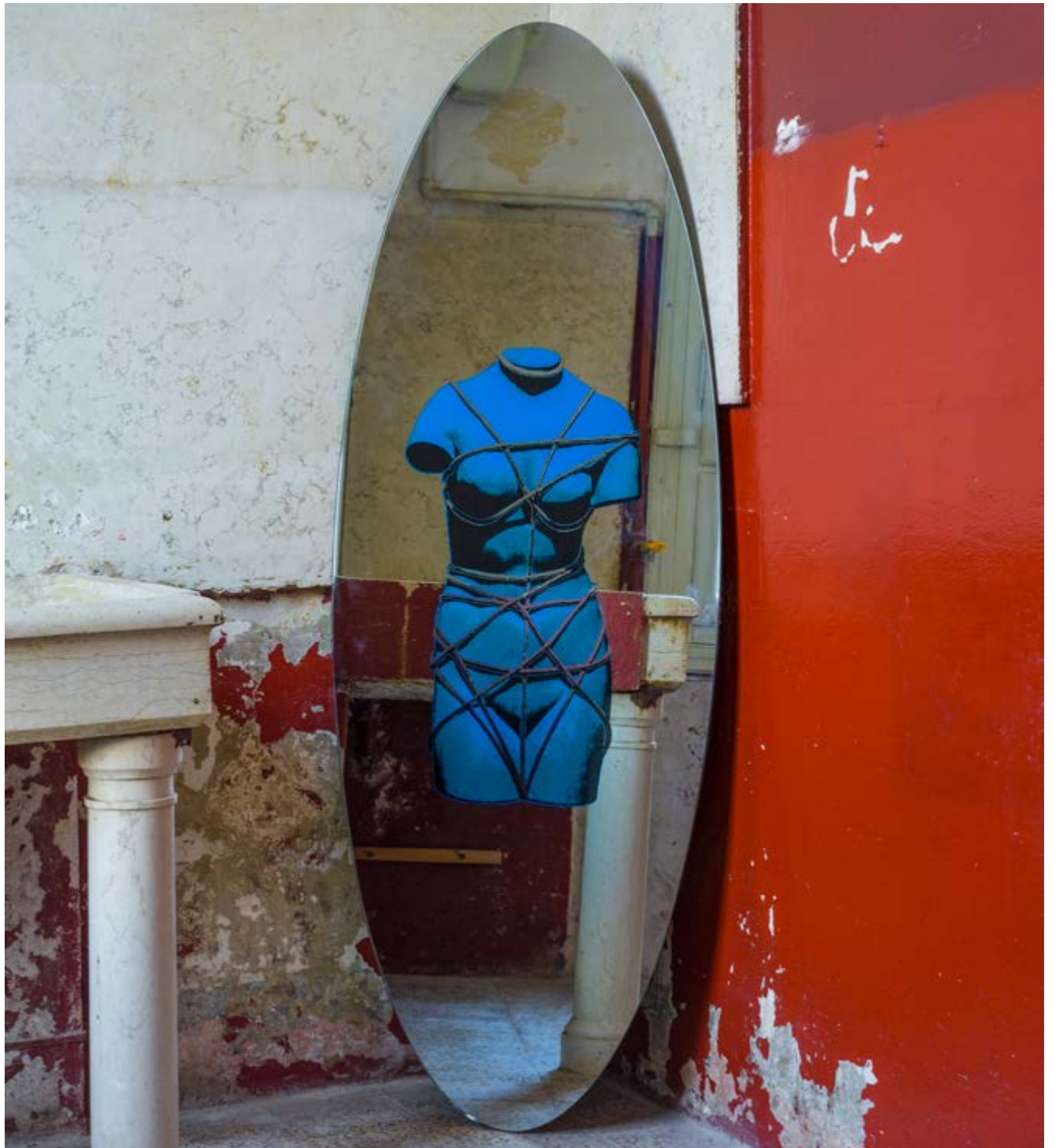

VENERE MIRROR TRIBUTE TO MAN RAY

Designer:
Dino Gavina

Materials:
silk-screened mirror,
MDF frame

Paradisoterrestre Edition

First production:
Simongavina Paradisoterrestre, 2004

W 68 | D 2,5 | H 170 cm
W 26,8 | D 0,9 | H 66,9 in

Man Ray once again surprises us with unexpected idea: an enigmatic, anticipating, suggesting work. A seed that will germinate in the following decades.

Dino Gavina met Man Ray in Paris. At the beginning the meeting was tense because the artist thought he was facing a journalist or a critic. Then his aggression turned into kindness as soon as he realized that Gavina wanted nothing more than to know him. From the corridor they went to the atelier, and stayed together for hours. At that precise moment an extraordinary lifelong friendship was born.

Venere mirror tribute to Man Ray was exhibited in the show "Kama – sex and design" at Triennale di Milano in 2012.

Venere © Man Ray, by SIAE 2021

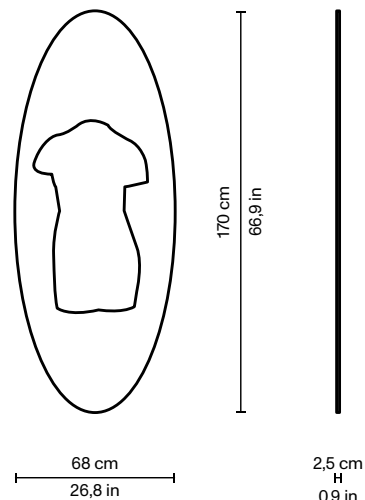

LA CASA NELLA CASA

DINO GAVINA

2022



LA CASA NELLA CASA

Designer:
Dino Gavina

Materials:
lacquered wood, carpet

Paradisoterrestre Edition 2022

First production:

Late Seventies for Dino Gavina's house

W 228 | D 295 | H 210 cm
W 89,7 | D 116 | H 82,6 in

1:1 reproduction of the "casa nella casa/house within the house", a sort of refuge, a "cube" in which to isolate oneself, which Dino Gavina created inside his own home.

Featured in Domus issue nr. 631 (September 1982), the "casa nella casa/house within the house" has been rebuilt thanks to the collaboration with his daughter Ilka Alessandra Gavina.

Presented for the first time at ADI Design Museum Compasso d'Oro in Milan for the 2022 Design Week, it has been exhibited later the same year in Bologna in the prestigious institutional venue of Sala d'Ercole in Palazzo d'Accursio on the occasion of the exhibition Cento % Dino to celebrate the centenary of Gavina's birth.

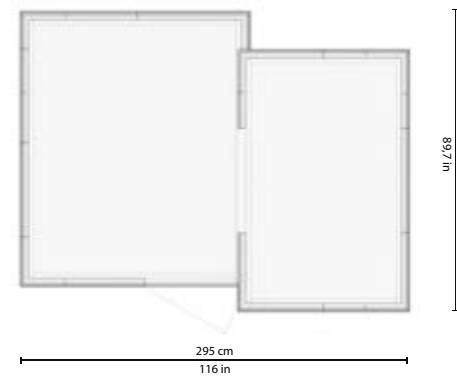
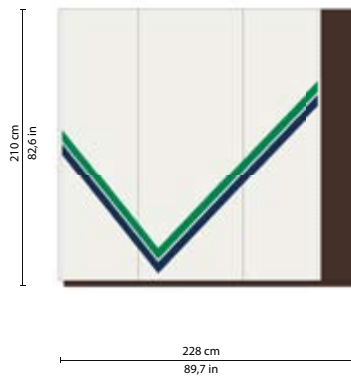
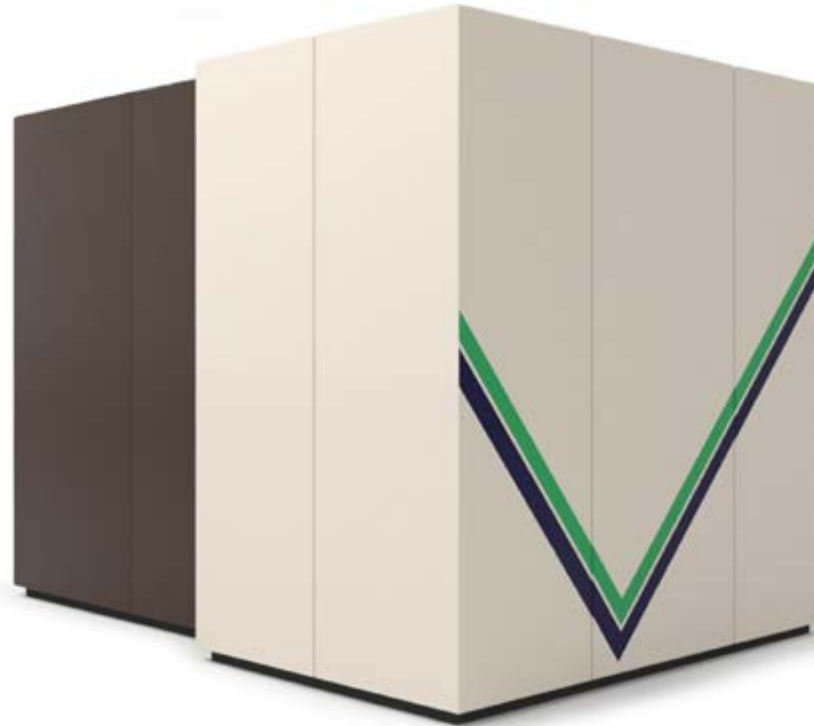

GIOVANNI
GENNARI

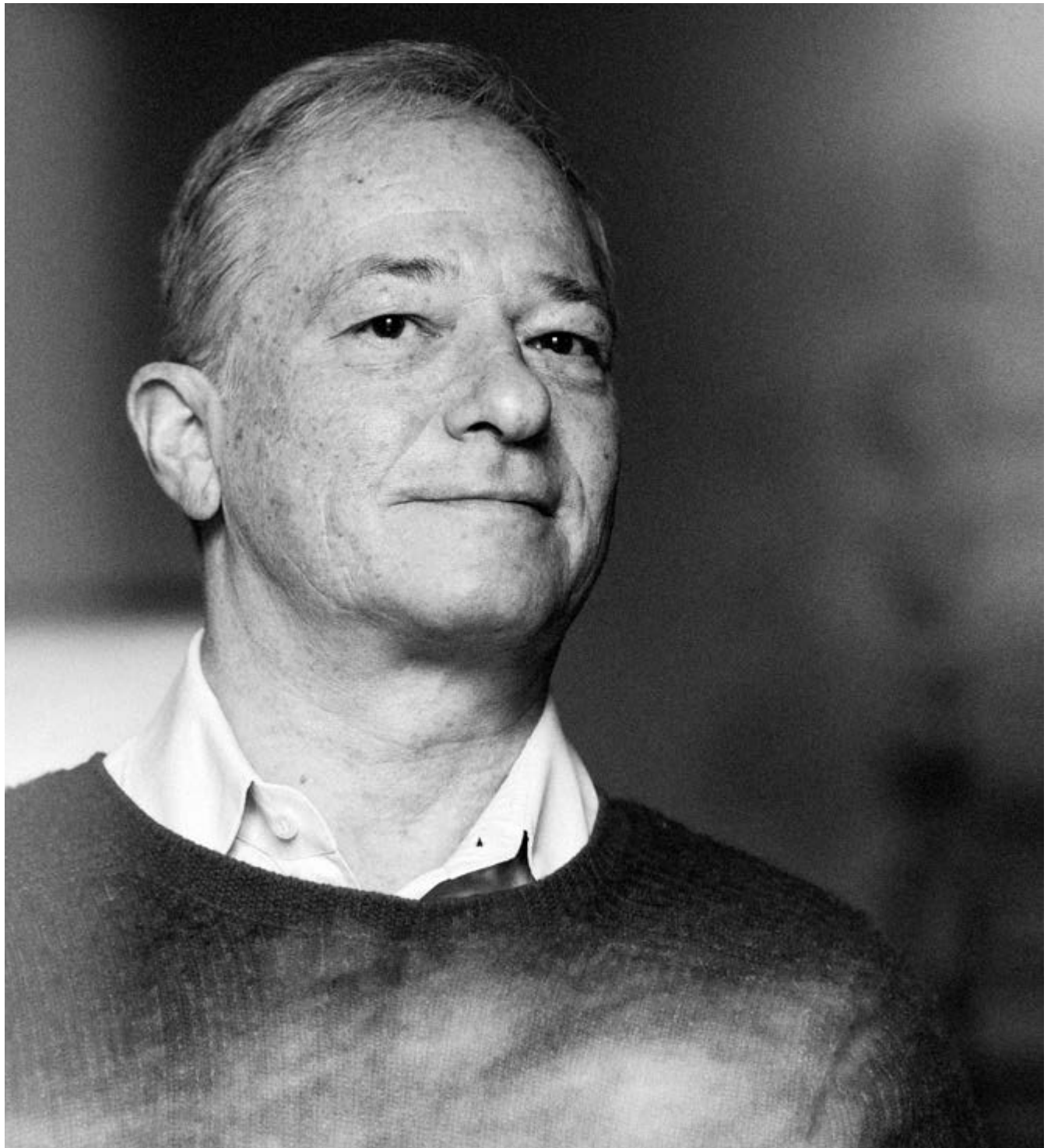

Giovanni Gennari's production is uniquely characterized by the ironic and playful association with thought and language.

Giovanni Gennari is a designer based in Milan. He started to work as a creative in the field of advertising and in 2005 he founded the design studio Nobody&co with Alisée Matta.

Nobody&co. made its debut at Fuorisalone at Pitti Living, during Salone del Mobile 2006. On that occasion Biblio-chaise, an armchair-bookcase that holds up to 5 metres of books, was presented for the first time.

Biblio-chaise is an immediate international success. Over the years, Biblio-chaise has also been invited to participate in numerous exhibitions and events around the world, France, Spain, Great Britain and Italy. In 2011 at London Design Week Biblio-chaise Luna was presented. During Fuorisalone 2013 in Milan, the Biblio-chaise and its Bibliopouf, a footstool inspired by the seat structure, were part of the exhibition 'Intorno al libro' (Around the book) curated by Beppe Finessi at the Poldi Pezzoli Museum. In May 2013 at Interiors London, the May Design Series, the Biblio-chaise Gold, 24 carat, was presented in a limited edition.

Nobody&co. collaborates with many brands and cultural institutions. For instance Buddino, a set of 4 pudding molds in the shape of a small Buddha, is chosen to represent Italy at Mudam, and sold at the MoMA in San Francisco and the Musée des Arts Decoratifs in Paris. In 2009, the Italian Art Director's Club chose to produce its Annual 2009/10 adopted the innovative design of the Nobody&co. catalogue, distinguished by its characteristic protruding corner base that allows it to stand out naturally among the books that crowd a library.

In 2017 Nobody&co. received the Milano Design Award.

In 2024 Giovanni Gennari starts a collaboration with Paradiso-terrestre and Biblio-chaise and Bibliopouf become part of its brand editions catalogue.

BIBLIOCHAISE

GIOVANNI
GENNARI

2024



BIBLIOCHAISE

Designer:
Giovanni Gennari

Paradisoterrestre Edition 2024

Materials:
wooden structure, polyurethane foam padding, upholstery in leather

W 101 | D 84,5 | H 74 cm
W 39,8 | D 33 | H 29,1 in

Bibliochoise, the armchair-bookcase by designer Giovanni Gennari, is now part of Paradisoterrestre Brand Editions catalogue.

Originally produced by Nobody&co., Bibliochoise was first previewed at Fuorisalone at Pitti Living, during Salone del Mobile 2006. Bibliochoise is an immediate international success and over the years, has been invited to participate to many exhibitions, events and tv shows all around the world.

The seat, which can hold up to 5 meters of books, allows to comfortably immerse into the reading surrounded by one's own personal and selected library. Bibliochoise, totally customizable, is available in three finishes: oak wood (natural or dyed), glossy lacquered wood and matte lacquered wood.

The ideal combination with Bibliochoise is Bibliopouf, with the same characteristics, which contains another 1.4 meters of books and allows for comfortable support for the feet.

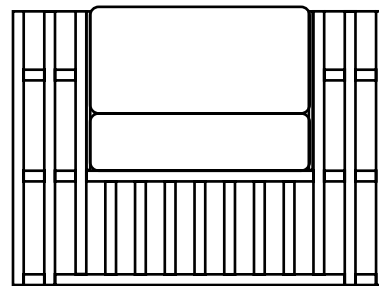

101 cm
39,8 in

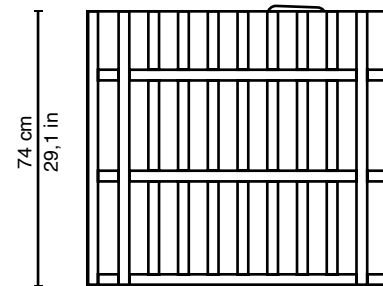

84,5 cm
33 in

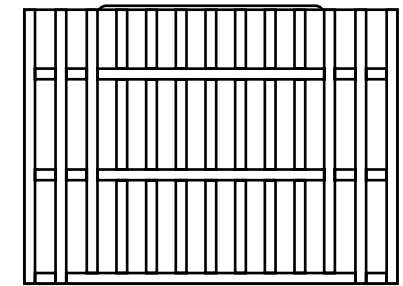

101 cm
39,8 in

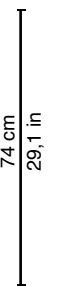

74 cm
29,1 in

BIBLIOPOUF

GIOVANNI
GENNARI

2024

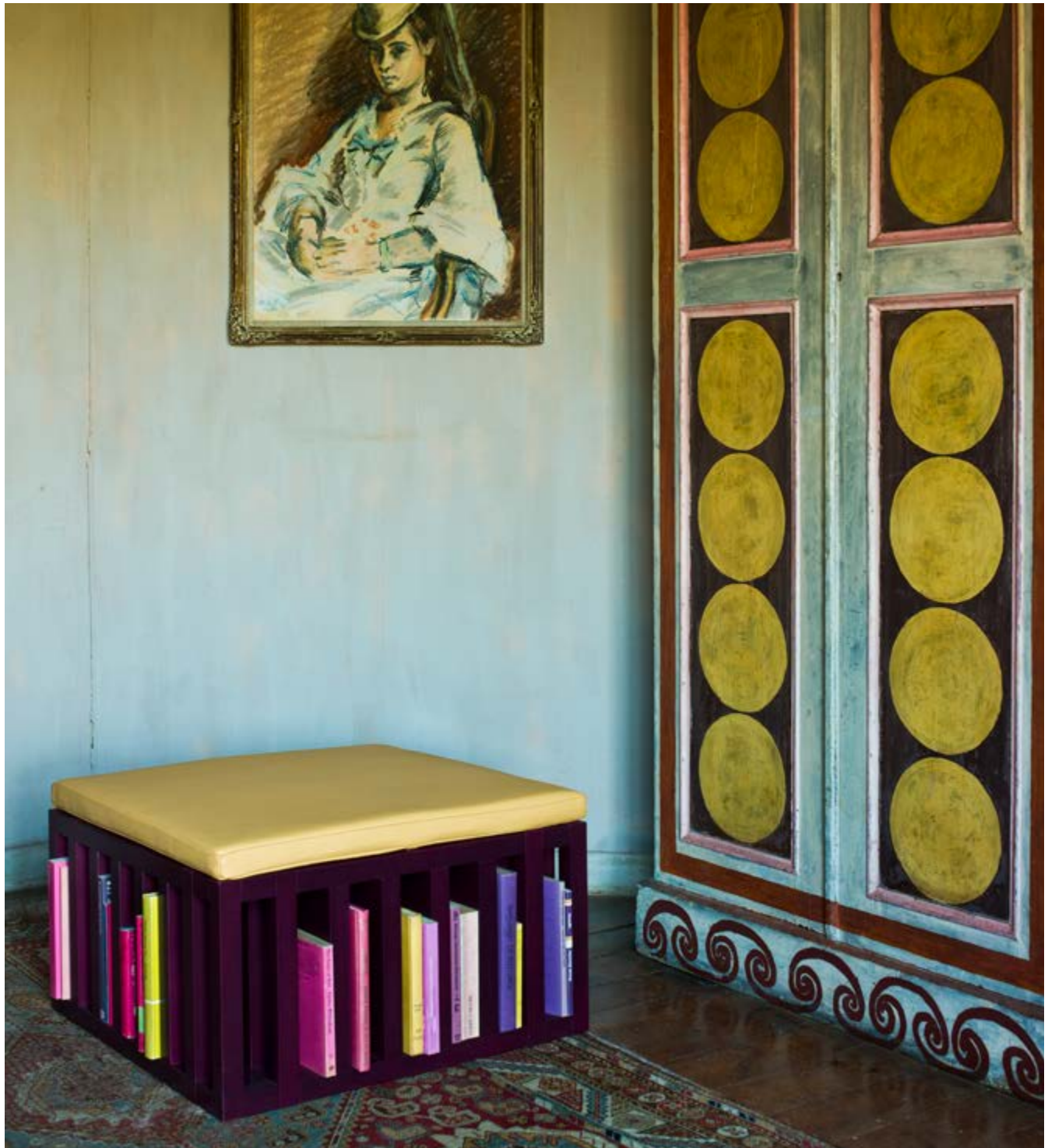

BIBLIOPOUF

Designer:
Giovanni Gennari

Paradisoterrestre Edition 2024

Materials:
wooden structure, polyurethane foam padding, upholstery in leather

W 60 | D 60 | H 40 cm
W 23,6 | D 23,6 | H 15,7 in

Bibliopouf, a footstool-bookcase by designer Giovanni Gennari, is now part of Paradisoterrestre Brand Editions catalogue.

Originally produced by Nobody&co., Bibliopouf was first previewed together with Bibliochoaise at Fuorisalone at Pitti Living, during Salone del Mobile 2006.

Bibliopouf can hold 1.4 metres of books and is perfect as a comfortable support in combination with the Bibliochoaise.

Totally customizable, the pouf is available in three finishes: oak wood (natural or dyed), glossy lacquered wood and matte lacquered wood.

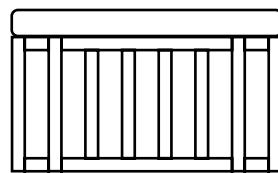

60 cm
23,6 in

40 cm
15,7 in

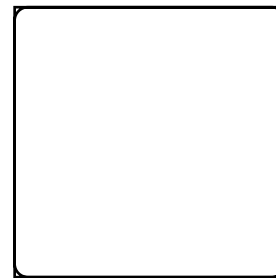

60 cm
23,6 in

KAZUHIDE TAKAHAMA

(1930 – 2010)



In Italy for the setting up of the Japanese pavilion at XI Triennale in Milan, in 1957 architect Kazuhide Takahama met Dino Gavina. A turning point in his career and the beginning of a lifelong collaboration.

Kazuhide Takahama was born on the Japanese island Kyushu. He graduated in architecture in 1953 from Tokyo Institute of Technology.

When he was 27 years old he became lecturer at the same University and he got his first job as a designer: he was in charge for the setting up of the Japanese pavilion for the XI Triennale in Milan in 1957. On that occasion he met Dino Gavina. This first meeting marked a turning point in his career and the beginning of a fruitful collaboration and deep friendship. Before going back to Japan, Kazuhide Takahama designed for Gavina the Naeko sofa (Takahama's first design produced in series and then marketed). During his stay in Japan he was professor at the University and curator of architectural and design projects, but he kept anyway in touch with Gavina, who finally convinced him to move to Italy. In 1963 he arrived in Italy together with his wife Naeko and their first daughter Kaori and settled in Bologna.

Many are the collaboration with Italian design companies such as: Gavina, Simon, Paradisoterrestre, B&B, Sirrah (then incorporated by Guzzini) just to name a few. His professional activity did not limit to furniture and lighting design: he designed indoor and outdoor spaces and followed the renovation of private residences and public works. Among them the facade and vip lounge of Guglielmo Marconi Airport and the bus stop canopies in Bologna.

NAEKO

KAZUhide
TAKAHAMA

1958

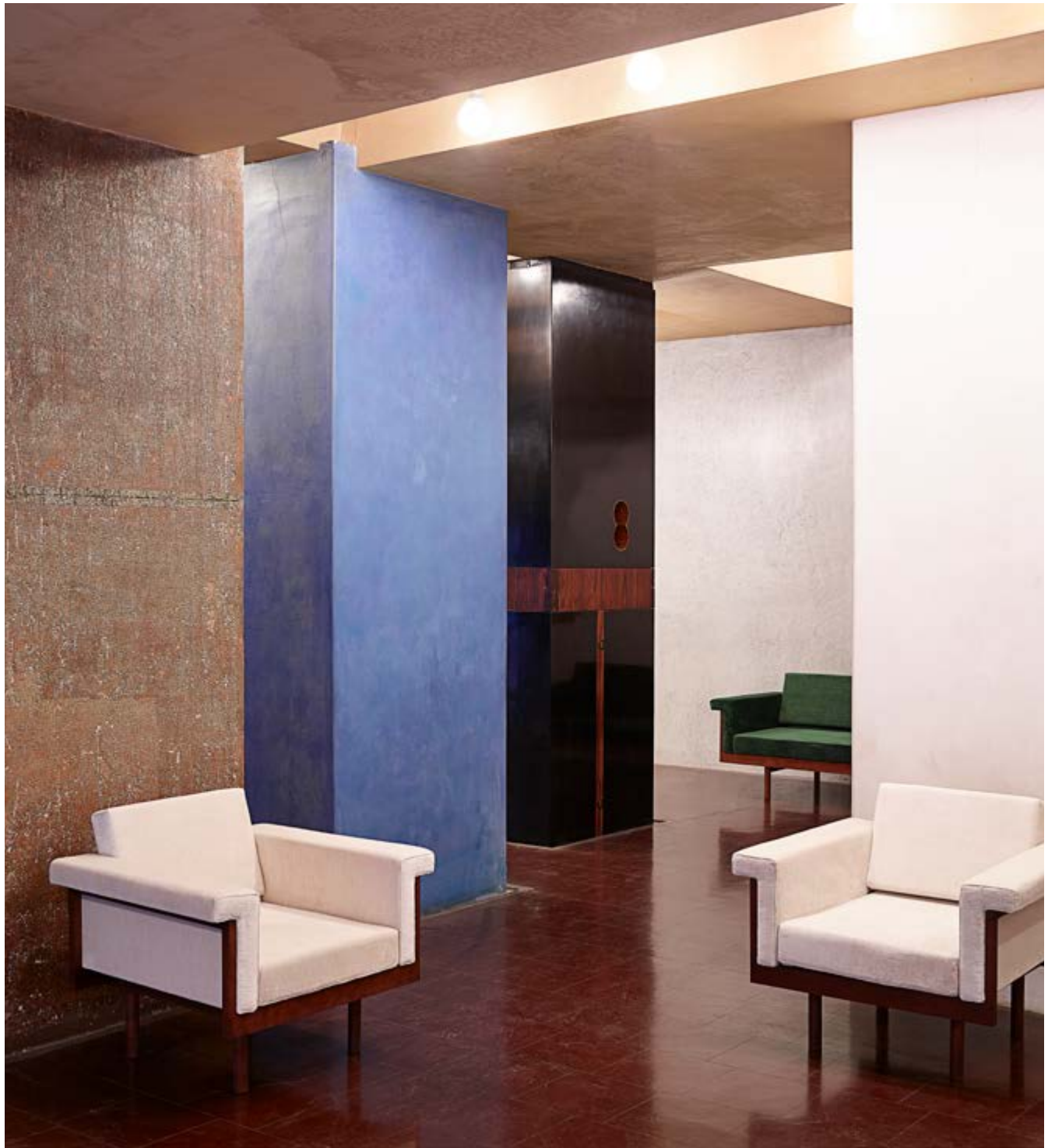

NAEKO ARMCHAIR

Designer:
Kazuhide Takahama

Paradisoterrestre Edition 2017

First production:
Gavina spa 1958

Materials:
cherry-wood structure, brass
finishes, polyurethane foam
padding, upholstery in linen
velvet

W 86 | D 74 | H 73 cm
W 33,9 | D 29,1 | H 28,7 in

This is the wooden version of a project developed when Kazuhide Takahama was in Italy to set up the Japanese pavilion at XI Triennale in Milan, 1956/57. On that occasion he met Dino Gavina, with whom he began a life long collaboration and friendship.

The first version of Naeko was produced in metal by Gavina spa, designed as a daily-bed thanks to its completely reclining backrest. It was immediately a great success, so that it was proposed also in a more valuable version in wood in 1958, exclusively as sofa with fixed backrest. In the same wooden version Naeko armchair was also produced.

A wonderful project that architect Takahama dedicated to his "Naeko", who later became his wife.

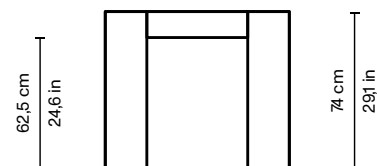
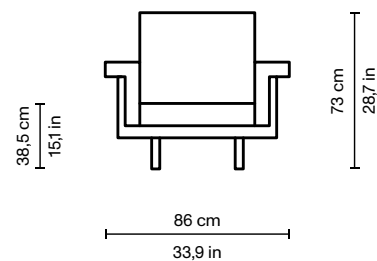

NAEKO ARMCHAIR SPECIAL EDITION KIKO KOSTADINOV

Designer:
Kazuhide Takahama

Paradisoterrestre Edition
2023

First production:
Gavina spa 1958

Materials:
cherry-wood structure, brass
finishes, polyurethane foam
padding, upholstery in fabrics
designed by Kiko Kostadinov

W 86 | D 74 | H 73 cm
W 33,9 | D 29,1 | H 28,7 in

A special edition by fashion designer Kiko Kostadinov of Naeko armchair designed by Kazuhide Takahama, a wonderful project that the Japanese architect dedicated to “Naeko”, who later became his wife.

Continuing in Takahama's tradition, Kostadinov upholsters Naeko armchair with fabrics that pull inspiration from his future wife Deanna Fanning, and the patterns used in Deanna's, and her sister and design partner Laura's, graduate collection.

Kostadinov's signature aesthetic is a perfect complement to the rigorous structures typical of Takahama's work.

This is the wooden version of a project developed when Kazuhide Takahama was in Italy to set up the Japanese pavilion at XI Triennale in Milan, 1956/57. On that occasion he met Dino Gavina, with whom he began a life long collaboration and friendship.

The first version of Naeko was produced in metal by Gavina spa, designed as a daily-bed thanks to its completely reclining backrest. It was immediately a great success, so that it was proposed also in a more valuable version in wood in 1958, exclusively as sofa with fixed backrest. In the same wooden version an armchair was also produced.

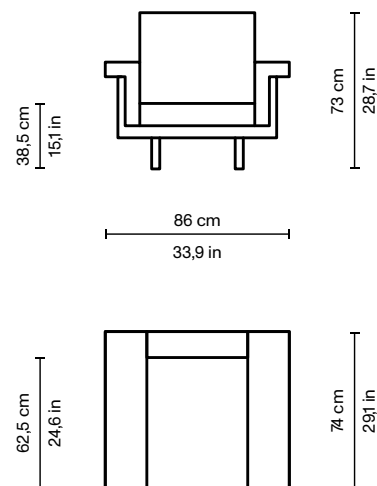

NAEKO SOFA

Designer:
Kazuhide Takahama

Paradisoterrestre Edition 2017

First production:
Gavina spa 1958

Materials:
cherry-wood structure, brass
finishes, polyurethane foam
padding, upholstery in linen
velvet

W 225 | D 77 | H 73 cm

This is the wooden version of a project developed when Kazuhide Takahama was in Italy to set up the Japanese pavilion at XI Triennale in Milan, 1956/57. On that occasion, he met Dino Gavina, with whom he began a lifelong collaboration and friendship.

The first version of Naeko was produced in metal by Gavina spa, designed as a daily-bed thanks to its completely reclining backrest. It was immediately a great success, so that it was proposed also in a more valuable version in wood in 1958, exclusively as sofa with fixed backrest. In the same wooden version an armchair was also produced.

A wonderful project that architect Takahama dedicated to his "Naeko", who later became his wife.

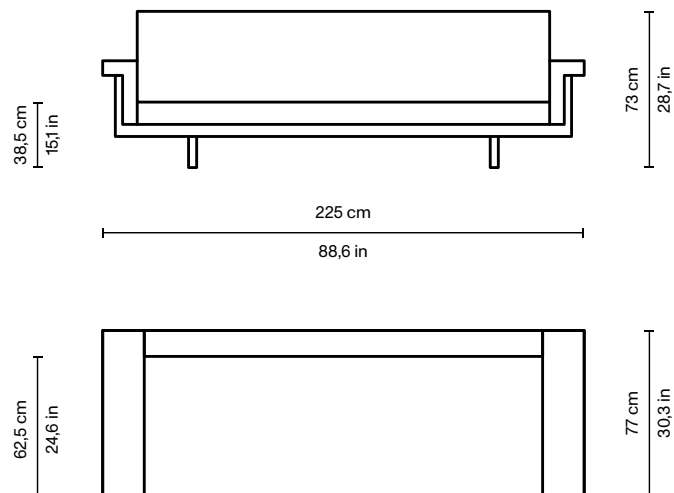

NAEKO SOFA SPECIAL EDITION KIKO KOSTADINOV

Designer:
Kazuhide Takahama

Paradisoterrestre Edition
2023

First production:
Gavina spa 1958

Materials:
cherry-wood structure, brass
finishes, polyurethane foam
padding, upholstery in fabrics
designed by Kiko Kostadinov

W 225 | D 77 | H 73 cm
W 88,6 | D 30,3 | H 28,7 in

A special edition by fashion designer Kiko Kostadinov of Naeko sofa designed by Kazuhide Takahama, a wonderful project that the Japanese architect dedicated to "Naeko", who later became his wife.

Continuing in Takahama's tradition, Kostadinov upholsters Naeko sofa with fabrics that pull inspiration from his future wife Deanna Fanning, and the patterns used in Deanna's, and her sister and design partner Laura's, graduate collection.

Kostadinov's signature aesthetic is a perfect complement to the rigorous structures typical of Takahama's work.

This is the wooden version of a project developed when Kazuhide Takahama was in Italy to set up the Japanese pavilion at XI Triennale in Milan, 1956/57. On that occasion he met Dino Gavina, with whom he began a life long collaboration and friendship.

The first version of Naeko was produced in metal by Gavina spa, designed as a daily-bed thanks to its completely reclining backrest. It was immediately a great success, so that it was proposed also in a more valuable version in wood in 1958, exclusively as sofa with fixed backrest. In the same wooden version an armchair was also produced.

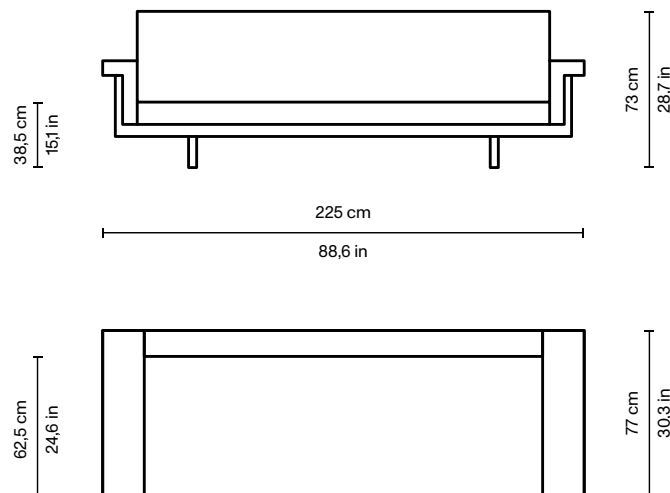

NAEKO CEILING LAMP

Designer:
Kazuhide Takahama

Paradisoterrestre Edition
2023

First production:
Sirrah 1984

Materials:
lacquered metal structure,
metal clips with brass
finishing, nacre buttons,
organza curtains, 1 bulb E14
led

W 55 | D 50 | H 115 cm
W 21,7 | D 19,7 | H 45,3 in

Designed by Japanese architect and designer Kazuhide Takahama for the Bolognese entrepreneur Dino Gavina in 1984 and produced by Sirrah, the ceiling lamp takes its name from the architect's wife, Naeko, like the sofa and armchair set.

The lamp is made by organza curtains, metal clips with brass finishing and nacre buttons.

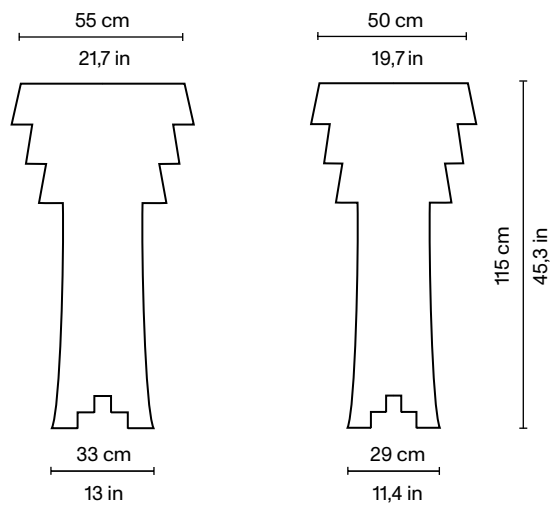

NAEKO CEILING LAMP SPECIAL EDITION BY KIKO KOSTADINOV

Designer:
Kazuhide Takahama

Paradisoterrestre Edition
2023

First production:
Sirrah 1984

Materials:
lacquered metal structure,
metal clips with brass
finishing, nacre buttons,
satin curtains, 1 bulb E14 led

W 55 | D 50 | H 115 cm
W 21,7 | D 19,7 | H 45,3 in

A special edition by fashion designer Kiko Kostadinov of Naeko ceiling lamp.

Designed by Japanese architect and designer Kazuhide Takahama for the Bolognese entrepreneur Dino Gavina in 1984 and produced by Sirrah, the ceiling lamp takes its name from the architect's wife, Naeko, like the sofa and armchair set.

Working from Takahama's original preparatory sketches, Kostadinov parses it through his distinct lens and reinterprets the possibilities the object allows, enriching the classic shape of Naeko ceiling lamp. Continuing in the tradition of its originator, Kostadinov pulls inspiration from his future wife Deanna Fanning and the geometrical patterns used in Deanna's, and her sister and design partner Laura's, graduate collection.

Naeko ceiling lamp can be customized combining white and geometrical pattern curtains.

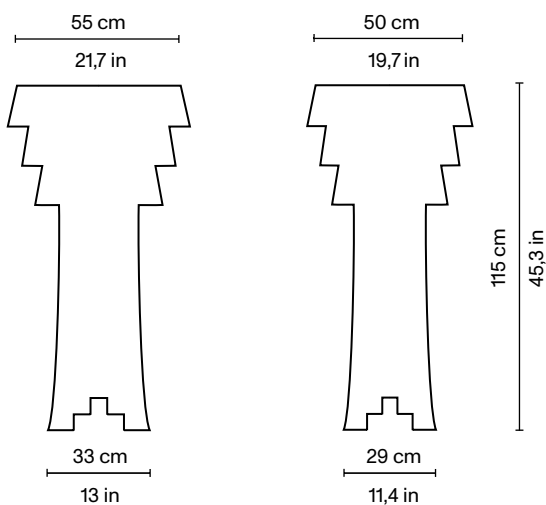

MARCEL

KAZUhide
TAKAHAMA

1965



MARCEL ARMCHAIR P

Designer:
Kazuhide Takahama

Paradisoterrestre Edition
2018

First production:
Gavina spa, 1965

Materials:
shaped polyurethane, po-
lished aluminum brackets.
Upholstery available in diffe-
rent fabrics

W 80 | D 88 | H 65 cm
W 31,5 | D 34,6 | H 25,6 in

The Marcel collection, a seating system developed in 1965, was a tribute by Dino Gavina to Marcel Duchamp, his dear friend. Sofas, armchairs and pouf designed by the architect Kazuhide Takahama, are the result of the fruitful and long-lasting artistic collaboration with Gavina.

This new type of modular system, based on a never-ending number of possible combinations in space, was unknown to the traditional definition of furniture and based on large shaped polyurethane blocks supported by aluminium brackets. Starting from the pouf in its elementary form, Takahama designed a series of complementary elements that combined functional as well as figurative needs, reinventing both the form of the seats and their supports.

The production of the Marcel collection fits with originality in the design of the 60s and has long influenced the Pop aesthetic, thus affirming creativity but also methodological rigour and industrial innovation. Takahama's aim was the search for a lasting quality in the long run together with a timeless original form.

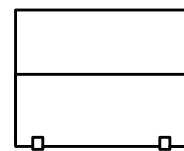

80 cm
31,5 in

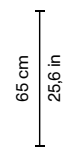

65 cm
25,6 in

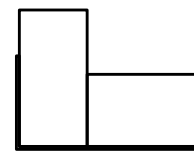

35 cm
13,8 in

88 cm
34,6 in

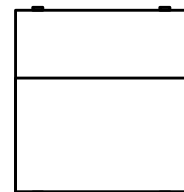

60 cm
23,6 in

MARCEL ARMCHAIR PP

Designer:
Kazuhide Takahama

Paradisoterrestre Edition
2018

First production:
Gavina spa, 1965

Materials:
shaped polyurethane, po-
lished aluminum brackets.
Upholstery available in diffe-
rent fabrics

W 80 | D 149 | H 65 cm
W 31,5 | D 58,7 | H 25,6 in

The Marcel collection, a seating system developed in 1965, was a tribute by Dino Gavina to Marcel Duchamp, his dear friend. Sofas, armchairs and pouf designed by the architect Kazuhide Takahama, are the result of the fruitful and long-lasting artistic collaboration with Gavina.

This new type of modular system, based on a never-ending number of possible combinations in space, was unknown to the traditional definition of furniture and based on large shaped polyurethane blocks supported by aluminium brackets. Starting from the pouf in its elementary form, Takahama designed a series of complementary elements that combined functional as well as figurative needs, reinventing both the form of the seats and their supports.

The production of the Marcel collection fits with originality in the design of the 60s and has long influenced the Pop aesthetic, thus affirming creativity but also methodological rigour and industrial innovation. Takahama's aim was the search for a lasting quality in the long run together with a timeless original form.

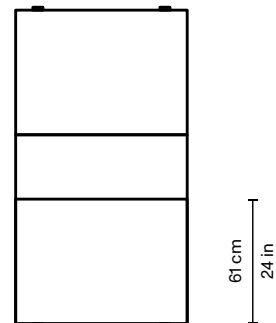
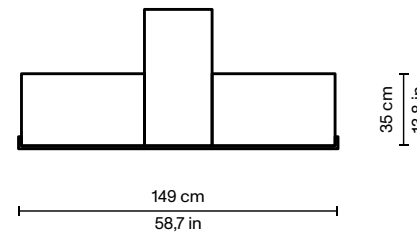
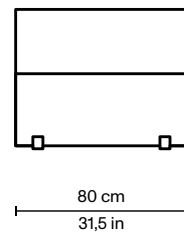

MARCEL POUF S

Designer:
Kazuhide Takahama

Paradisoterrestre Edition
2018

First production:
Gavina spa, 1965

Materials:
shaped polyurethane, po-
lished aluminum brackets.
Upholstery available in diffe-
rent fabrics

W 80 | D 61 | H 35 cm
W 31,5 | D 24 | H 13,8 in

The Marcel collection, a seating system developed in 1965, was a tribute by Dino Gavina to Marcel Duchamp, his dear friend. Sofas, armchairs and pouf designed by the architect Kazuhide Takahama, are the result of the fruitful and long-lasting artistic collaboration with Gavina.

This new type of modular system, based on a never-ending number of possible combinations in space, was unknown to the traditional definition of furniture and based on large shaped polyurethane blocks supported by aluminium brackets. Starting from the pouf in its elementary form, Takahama designed a series of complementary elements that combined functional as well as figurative needs, reinventing both the form of the seats and their supports.

The production of the Marcel collection fits with originality in the design of the 60s and has long influenced the Pop aesthetic, thus affirming creativity but also methodological rigour and industrial innovation. Takahama's aim was the search for a lasting quality in the long run together with a timeless original form.

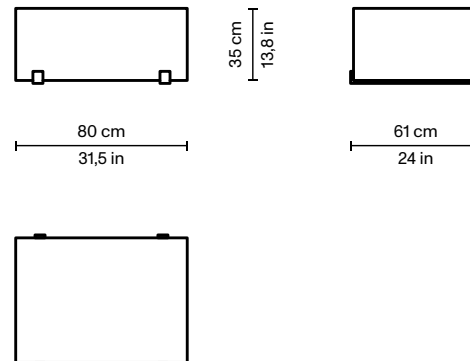

MARCEL SOFA D

Designer:
Kazuhide Takahama

Paradisoterrestre Edition
2018

First production:
Gavina spa, 1965

Materials:
shaped polyurethane, po-
lished aluminum brackets.
Upholstery available in diffe-
rent fabrics

W 248 | D 88 | H 65 cm
W 97,6 | D 34,6 | H 25,6 in

The Marcel collection, a seating system developed in 1965, was a tribute by Dino Gavina to Marcel Duchamp, his dear friend. Sofas, armchairs and pouf designed by the architect Kazuhide Takahama, are the result of the fruitful and long-lasting artistic collaboration with Gavina.

This new type of modular system, based on a never-ending number of possible combinations in space, was unknown to the traditional definition of furniture and based on large shaped polyurethane blocks supported by aluminium brackets. Starting from the pouf in its elementary form, Takahama designed a series of complementary elements that combined functional as well as figurative needs, reinventing both the form of the seats and their supports.

The production of the Marcel collection fits with originality in the design of the 60s and has long influenced the Pop aesthetic, thus affirming creativity but also methodological rigour and industrial innovation. Takahama's aim was the search for a lasting quality in the long run together with a timeless original form.

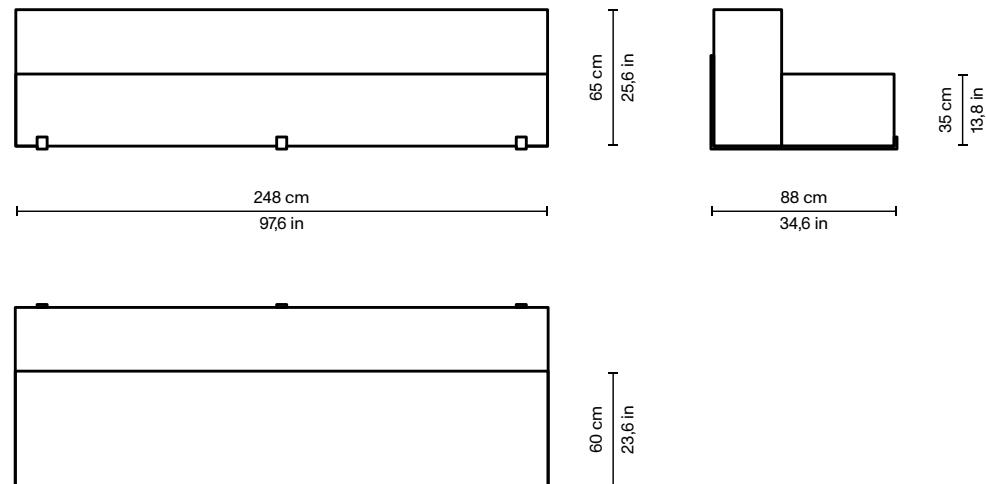

MARCEL DOUBLE SOFA DD

Designer:
Kazuhide Takahama

Paradisoterrestre Edition
2018

First production:
Gavina spa, 1965

Materials:
shaped polyurethane, po-
lished aluminum brackets.
Upholstery available in diffe-
rent fabrics

W 248 | D 149 | H 65 cm
W 97,6 | D 58,7 | H 25,6 in

The Marcel collection, a seating system developed in 1965, was a tribute by Dino Gavina to Marcel Duchamp, his dear friend. Sofas, armchairs and pouf designed by the architect Kazuhide Takahama, are the result of the fruitful and long-lasting artistic collaboration with Gavina.

This new type of modular system, based on a never-ending number of possible combinations in space, was unknown to the traditional definition of furniture and based on large shaped polyurethane blocks supported by aluminium brackets. Starting from the pouf in its elementary form, Takahama designed a series of complementary elements that combined functional as well as figurative needs, reinventing both the form of the seats and their supports.

The production of the Marcel collection fits with originality in the design of the 60s and has long influenced the Pop aesthetic, thus affirming creativity but also methodological rigour and industrial innovation. Takahama's aim was the search for a lasting quality in the long run together with a timeless original form.

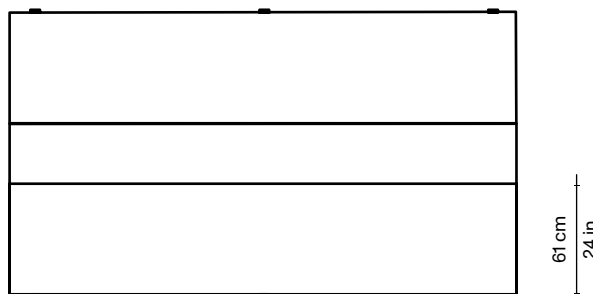
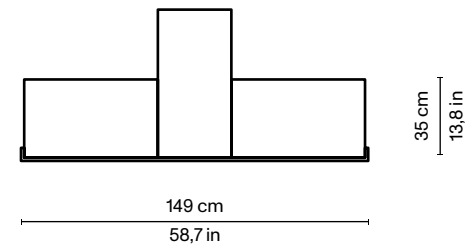
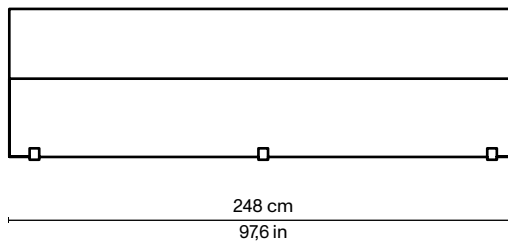

MARCEL SOFA L

Designer:
Kazuhide Takahama

Paradisoterrestre Edition
2018

First production:
Gavina spa, 1965

Materials:
shaped polyurethane, po-
lished aluminum brackets.
Upholstery available in diffe-
rent fabrics

W 150 | D 88 | H 65 cm
W 59 | D 34,6 | H 25,6 in

The Marcel collection, a seating system developed in 1965, was a tribute by Dino Gavina to Marcel Duchamp, his dear friend. Sofas, armchairs and pouf designed by the architect Kazuhide Takahama, are the result of the fruitful and long-lasting artistic collaboration with Gavina.

This new type of modular system, based on a never-ending number of possible combinations in space, was unknown to the traditional definition of furniture and based on large shaped polyurethane blocks supported by aluminium brackets. Starting from the pouf in its elementary form, Takahama designed a series of complementary elements that combined functional as well as figurative needs, reinventing both the form of the seats and their supports.

The production of the Marcel collection fits with originality in the design of the 60s and has long influenced the Pop aesthetic, thus affirming creativity but also methodological rigour and industrial innovation. Takahama's aim was the search for a lasting quality in the long run together with a timeless original form.

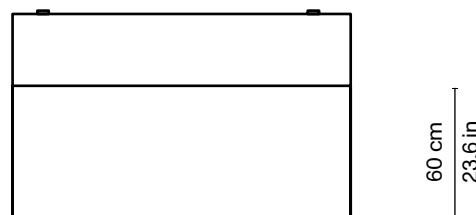
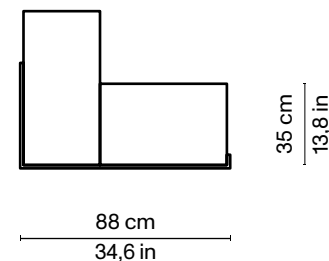
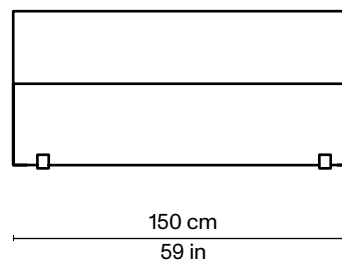

MARCEL DOUBLE SOFA LL

Designer:
Kazuhide Takahama

Paradisoterrestre Edition
2018

First production:
Gavina spa, 1965

Materials:
shaped polyurethane, po-
lished aluminum brackets.
Upholstery available in diffe-
rent fabrics

W 150 | D 149 | H 65 cm
W 59 | D 58,7 | H 25,6 in

The Marcel collection, a seating system developed in 1965, was a tribute by Dino Gavina to Marcel Duchamp, his dear friend. Sofas, armchairs and pouf designed by the architect Kazuhide Takahama, are the result of the fruitful and long-lasting artistic collaboration with Gavina.

This new type of modular system, based on a never-ending number of possible combinations in space, was unknown to the traditional definition of furniture and based on large shaped polyurethane blocks supported by aluminium brackets. Starting from the pouf in its elementary form, Takahama designed a series of complementary elements that combined functional as well as figurative needs, reinventing both the form of the seats and their supports.

The production of the Marcel collection fits with originality in the design of the 60s and has long influenced the Pop aesthetic, thus affirming creativity but also methodological rigour and industrial innovation. Takahama's aim was the search for a lasting quality in the long run together with a timeless original form.

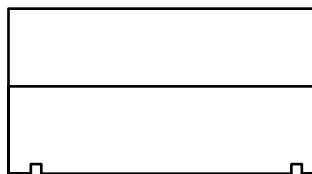

150 cm
59 in

65 cm
25,6 in

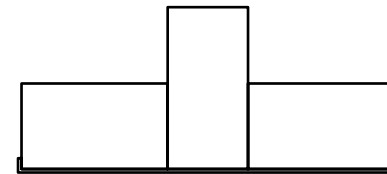

149 cm
58,7 in

35 cm
13,8 in

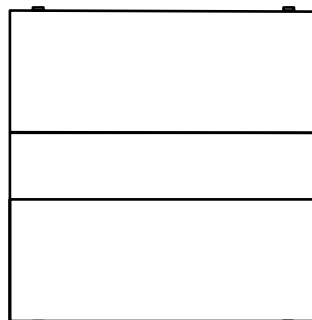

61 cm
24 in

MARCEL POUF SD

Designer:
Kazuhide Takahama

Paradisoterrestre Edition
2018

First production:
Gavina spa, 1965

Materials:
shaped polyurethane, po-
lished aluminum brackets.
Upholstery available in diffe-
rent fabrics

W 248 | D 61 | H 35 cm
W 97,6 | D 24 | H 13,8 in

The Marcel collection, a seating system developed in 1965, was a tribute by Dino Gavina to Marcel Duchamp, his dear friend. Sofas, armchairs and pouf designed by the architect Kazuhide Takahama, are the result of the fruitful and long-lasting artistic collaboration with Gavina.

This new type of modular system, based on a never-ending number of possible combinations in space, was unknown to the traditional definition of furniture and based on large shaped polyurethane blocks supported by aluminium brackets. Starting from the pouf in its elementary form, Takahama designed a series of complementary elements that combined functional as well as figurative needs, reinventing both the form of the seats and their supports.

The production of the Marcel collection fits with originality in the design of the 60s and has long influenced the Pop aesthetic, thus affirming creativity but also methodological rigour and industrial innovation. Takahama's aim was the search for a lasting quality in the long run together with a timeless original form.

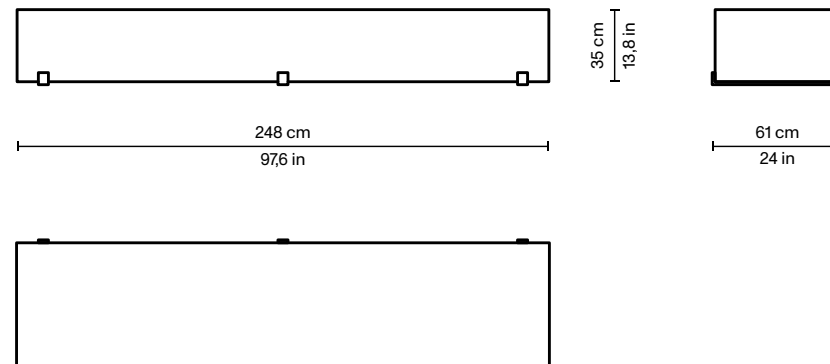

MARCEL BED

Designer:
Kazuhide Takahama

element. Upholstery available
in different fabrics

Paradisoterrestre Edition
2019

First production:
Simon, 1974

Headboard:
W 170 | D 27 | H 74 cm
W 66,9 | D 10,6 | H 29,1 in

Materials:
shaped polyurethane structure
on a wooden base, steel
tube attachment and foot

Bed:
W 170 | D 200 | H 30 cm
W 66,9 | D 78,7 | H 11,8 in

In 1974 this bed was added to Marcel collection, a seating system developed in 1965, as a tribute by Dino Gavina to Marcel Duchamp, his dear friend. Sofas, armchairs and pouf designed by the architect Kazuhide Takahama, are the result of the fruitful and long-lasting artistic collaboration with Gavina.

This new type of modular system, based on a never-ending number of possible combinations in space, was unknown to the traditional definition of furniture and based on large shaped polyurethane blocks supported by aluminium brackets. Starting from the pouf in its elementary form, Takahama designed a series of complementary elements that combined functional as well as figurative needs, reinventing both the form of the seats and their supports.

The production of the Marcel collection fits with originality in the design of the 60s and has long influenced the Pop aesthetic, thus affirming creativity but also methodological rigour and industrial innovation. Takahama's aim was the search for a lasting quality in the long run together with a timeless original form.

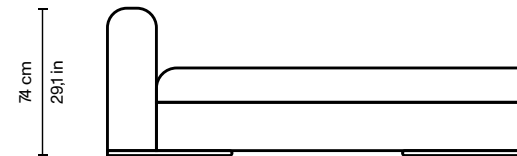

30 cm
11,8 in

200 cm
78,7 in

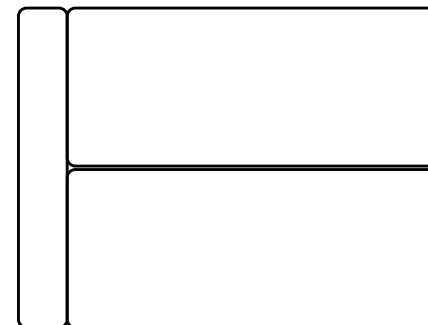

MANTILLA

KAZUhide
TAKAHAMA

1974



MANTILLA ARMCHAIR

Designer: foam structure, chenille velvet
Kazuhide Takahama cloth with snaps fitting on
metal rods inserted into the
Paradisoterrestre Edition 2017 structure

First production: Colours:
Simon International, 1974 green, blue, white, black

Materials: W 95 | D 86 | H 70 cm
plywood base, polyurethane W 37,4 | D 33,8 | H 27,5 in

It suits to the silence and quiet elegance of the morning light while in the evening it is right for very large or smaller rooms. So mutable and perfect to change its cloth in a flash, it can be dressed up for a dinner and easily undressed if it gets dirty, every day in a different guise.

Mantilla was so called because of the mantle which covers it, thus distinguishing its look. The idea comes from an ancient memory: taking care of the furniture of the holiday mansions by covering them with fabrics during the long winter months.

Each piece has its cloth which is perfectly contoured on the structure and hooked by means of suitable pressure buttons, so that it is easily replaceable. The armchair can be equipped with more than one cloth, thus renewing the look of a room depending on the season, but even for particular events, or used without cloth.

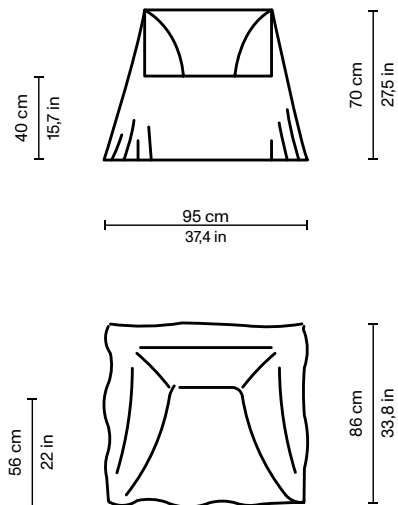

MANTILLA SOFA 160

Designer: foam structure, chenille velvet
Kazuhide Takahama cloth with snaps fitting on
metal rods inserted into the
Paradisoterrestre Edition 2017 structure

First production: Colours:
Simon International, 1974 green, blue, white, black

Materials: W 160 | D 86 | H 70 cm
plywood base, polyurethane W 63 | D 33,8 | H 27,5 in

Mantilla sofa 160 by Kazuhide Takahama suits to the silence and quiet elegance of the morning light while in the evening it is right for very large or smaller rooms. So mutable and perfect to change its cloth in a flash, it can be dressed up for a dinner and easily undressed if it gets dirty, every day in a different guise.

Mantilla was so called because of the mantle which covers it, thus distinguishing its look. The idea comes from an ancient memory: taking care of the furniture of the holiday mansions by covering them with fabrics during the long winter months.

Each piece has its cloth which is perfectly contoured on the structure and hooked by means of suitable pressure buttons, so that it is easily replaceable. The sofa can be equipped with more than one cloth, thus renewing the look of a room depending on the season, but even for particular events, or used without cloth.

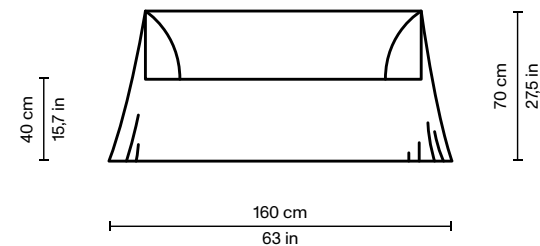

MANTILLA SOFA 225

Designer:	foam structure, chenille velvet
Kazuhide Takahama	cloth with snaps fitting on
Paradisoterrestre Edition 2017	metal rods inserted into the
	structure
First production:	Colours:
Simon International, 1974	green, blue, white, black
Materials:	W 225 D 86 H 70 cm
plywood base, polyurethane	W 88,6 D 33,8 H 27,5 in

It suits to the silence and quiet elegance of the morning light while in the evening it is right for very large or smaller rooms. So mutable and perfect to change its cloth in a flash, it can be dressed up for a dinner and easily undressed if it gets dirty, every day in a different guise.

Mantilla was so called because of the mantle which covers it, thus distinguishing its look. The idea comes from an ancient memory: taking care of the furniture of the holiday mansions by covering them with fabrics during the long winter months.

Each piece has its cloth which is perfectly contoured on the structure and hooked by means of suitable pressure buttons, so that it is easily replaceable. The armchair can be equipped with more than one cloth, thus renewing the look of a room depending on the season, but even for particular events, or used without cloth.

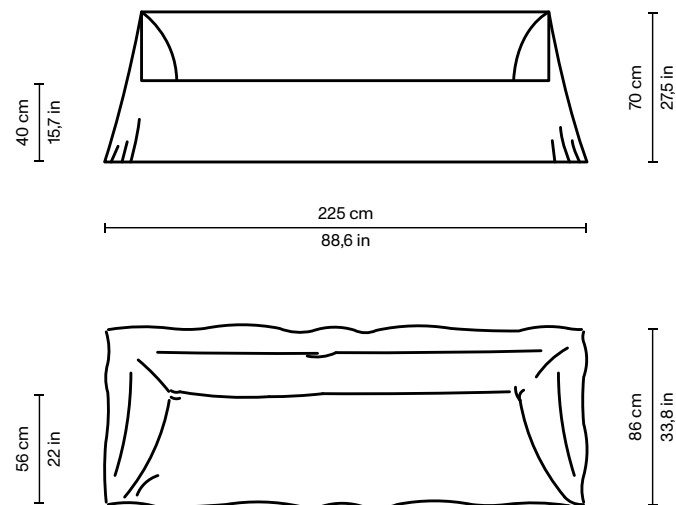

MANTILLA SOFA 290

Designer: foam structure, chenille velvet
Kazuhide Takahama cloth with snaps fitting on
metal rods inserted into the
Paradisoterrestre Edition 2017 structure

First production: Colours:
Simon International, 1974 green, blue, white, black

Materials: W 290 | D 86 | H 70 cm
plywood base, polyurethane W 114,1 | D 33,8 | H 27,5 in

It suits to the silence and quiet elegance of the morning light while in the evening it is right for very large or smaller rooms. So mutable and perfect to change its cloth in a flash, it can be dressed up for a dinner and easily undressed if it gets dirty, every day in a different guise.

Mantilla was so called because of the mantle which covers it, thus distinguishing its look. The idea comes from an ancient memory: taking care of the furniture of the holiday mansions by covering them with fabrics during the long winter months.

Each piece has its cloth which is perfectly contoured on the structure and hooked by means of suitable pressure buttons, so that it is easily replaceable. The sofa can be equipped with more than one cloth, thus renewing the look of a room depending on the season, but even for particular events, or used without cloth.

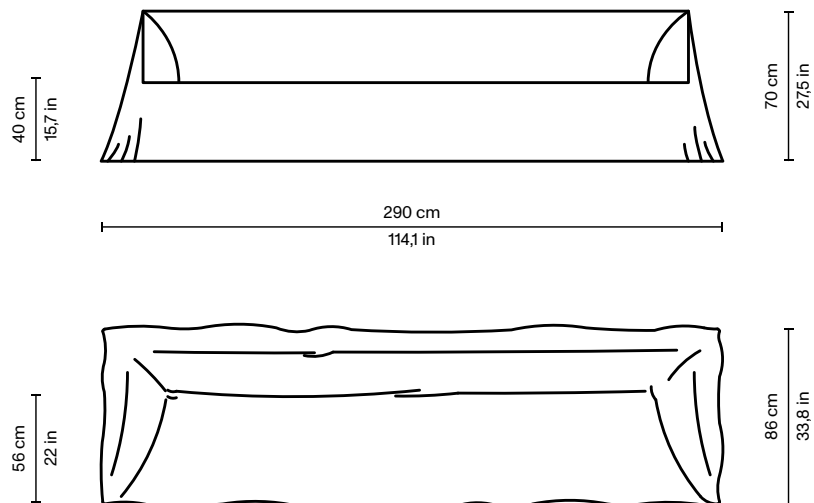

ELMO

KAZUhide
TAKAHAMA

1984



ELMO

Designer:
Kazuhide Takahama

Materials:
enameled pottery

Paradisoterrestre Edition 2017 Colours:
grey, blue, white

First production:
Cooperativa Ceramica d'Imola, 1984

W 34 | H 29 | Ø 28 cm
W 13,4 | H 11,4 | Ø 11 in

In the early 80s Mario Lispi organized an exhibition dedicated to the ceramics art and suggested to his friend Kazuhide Takahama to design a work.

Although the Japanese architect had used this kind of material for the first time, his work Elmo – of great impact – was unexpectedly the most beautiful of the show. His fairy-tale work, a sublime abstract fusion with a huge aesthetic strength tells the ancient Eastern concept of containers – one inside the other – and also evoking Vikings' helmets magical shapes.

Signed by Takahama, it is produced in a limited edition of 12 for each colour.

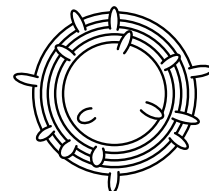
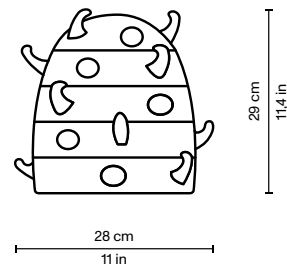

MAN RAY

(1890 – 1976)

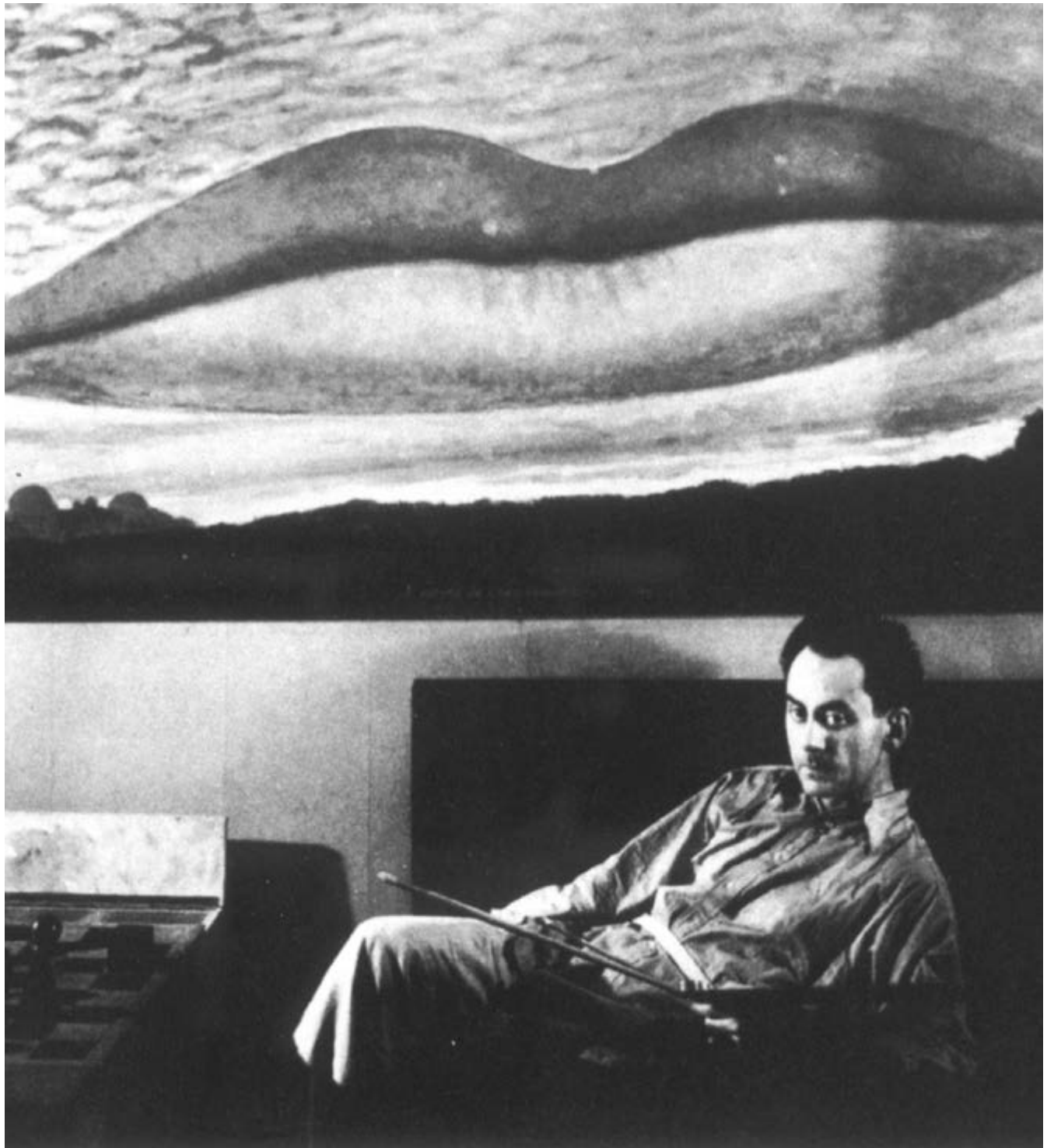

Emblematic figure for the development of avant-garde movements Dadaism and Surrealism both in Europe and in America, Man Ray is considered one of the most significant artists of 20th century.

Among the most versatile and creative artists of the twentieth century, Man Ray was one of the most radical and multifaceted representatives of Dadaism and Surrealism. Born in Philadelphia in 1890, he experienced the Greenwich Village at the time of the avant-garde, following the famous Armory show in New York in 1913; Paris in the Twenties and Thirties, in which he played a key role in the Dada and Surrealist Movements; the Hollywood of the 1940s, where he joined other European war refugees; and finally Paris again until his death in 1976.

In Paris Man Ray met Dino Gavina. At the beginning the meeting was tense because the artist thought he was facing a journalist or a critic. Then his aggression turned into kindness as soon as he realized that Gavina wanted nothing more than to know him. From the corridor they went to the atelier, and stayed together for hours. At that precise moment an extraordinary lifelong friendship and collaboration was born.

RUE FÉROU

MAN RAY

1972



RUE FÉROU

Designer: Man Ray	cardboard canvas light diffuser
Paradisoterrestre Edition	Colours: diffuser in white, black, green, blue
First production: Sirrah, 1972	
Materials:	Ø 30 H 65 cm
brass-plated metal structure,	Ø 11,8 H 25,6 in

“A flash of joy and poetry. The simplest directional lampshade in history meets the objet trouvé. The perfect object was born.”

In the studio located in Rue Férou there were some light bulbs, scattered in the room, holding some cardboards hats, simply directing the light with the minimum. “I have always made everything with nothing” Man Ray says.

Dino Gavina had the idea to use them and Man Ray gave personally the specifications for producing a lamp whose lampshade he made by his hand as sample. The task of developing the design was given to Giulietto Cacciari, who produced the first Rue Férou model with brass-plated metal holder base.

Rue Férou, © Man Ray Trust, by SIAE 2019

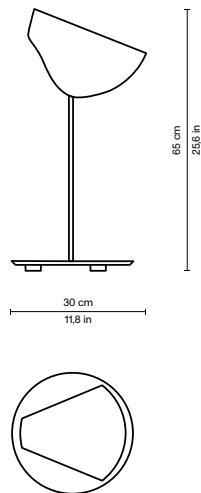

LE TÉMOIN

MAN RAY

1971



LE TÉMOIN

Designer:
Man Ray

Materials:
wood structure, synthetic
leather upholstery, hand painted
methacrylate

Paradisoterrestre Edition
2020

First production:
Simon International
– Ultramobile collection, 1971

W 154 | D 40 | H 70 cm
W 60,5 | D 16 | H 27,5 in

Part of the historic and revolutionary operation Ultramobile, conceived by Dino Gavina in 1971 with the aim of surprisingly adapting the surrealist object to everyday use, Le Témoin by Man Ray is an eye that watches you insistently, an indiscreet presence; you turn it and it turns into an unexpected seat.

The great artist Man Ray and the Bolognese entrepreneur Dino Gavina were linked by an extraordinary friendship and collaboration: the idea for Le Témoin was born from a gift exchanged between the two – an oval-shaped cookie box that Gavina gave to Man Ray and on which the artist painted a big eye before giving it back to his friend.

“The large eye, the witness, insistently observes you in your home, when your conscience cannot withstand it, then you turn it over and it immediately turns into a sofa.” – Man Ray

A witness to our habits within the domestic landscape, the eye by Man Ray is a “furniture of poetry”.

Le Témoin is at the same time a practical response to functional needs and a “totem evoking wonder, a presence that pulsates and breathes in your home, a vital and sardonic aggression, poetry frozen in a flash of joy” (from the text of the first leaflet “Ultramobile”, 1971).

Le Témoin, © Man Ray Trust, by SIAE 2020

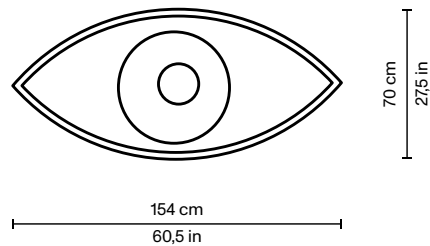

MARIYO YAGI

(1948 – 2024)



Recipient of main awards, Japanese artist Mariyo Yagi is renowned for her spiral sculptures, the result of a personal theoretical research on the word “Nawa” (rope in Japanese, which metaphorically connects Humanity).

The artist Mariyo Yagi (1948-2024) was born in Kobe, Japan. She graduated in Fine Arts at the Kyoto City University of Art. From 1973 to 1976 she worked for sculptor and architect Isamu Noguchi. In 1973 at Venice Biennale she met Carlo Scarpa who introduced her to Dino Gavina. From 1995 to 1998 she was professor at Kobe Women's University.

Recipient of main awards, including in 1995 Urban Art Award, Maubege (France) and Urban Design Award, Toyonaka City (Japan); in 1999 Honorary Doctorate of Humanities (Anaheim University, USA) and in 2003 the 21st Kyoto Prefecture Culture Merits Prize (Japan).

Her best-known artworks, the result of a personal theoretical research on the word “Nawa” (rope in Japanese, which metaphorically connects Humanity), are spiral sculptures in diverse materials and dimensions, even monumental, that can be found in Europe, the United States and Asia.

Her approach to art is versatile and her research is always evolving, open to new ideas, changes and possibilities. With her environmental projects, monumental earthworks and public performances Mariyo Yagi transforms communities and the built environment through her unconventional interactive art practice.

GARBO

MARIYO YAGI

1973



GARBO Q

Designer:
Mariyo Yagi

Paradisoterrestre Edition 2017

First production:
Sirrah, 1973

Materials:
lacquered metal structure
and fabric fringes, 3 leds

Colours:
white ceiling lamp, white
fringe

W 23 | D 23 | H 160 or 300 cm
W 9 | D 9 | H 63 or 118,1 in

A light sparkling cascade, a transparent wall of wires, a translucent mirror moving with a breath of air, thus creating a bright sparkle, a magic presence in a space. Garbo may be used to divide rooms or to emphasize something exhibited.

Square-shaped ceiling element with applied white fabric fringe, easily removable, washable, heat-resistant and fire-proof. Heights are the following: 300 cm from the ceiling to the ground and 160 cm for table height. It is possible to cut off part of the fringe in order to reduce the height.

Applied both individually or side by side, with their casual and random placement, they live freely in the space. They are bright diaphragms separating an area without limiting it since you can cross them. Placed in front of a window they look like floating against the light.

The name Garbo was suggested by Dino Gavina as a tribute to the actress Greta Garbo, evidencing its unique beauty and elegance.

Garbo is part of the permanent collection of Tokyo National Museum of Modern Art and of La Galleria Nazionale in Rome.

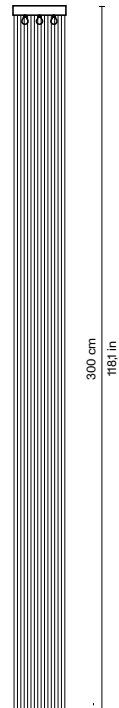
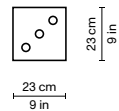
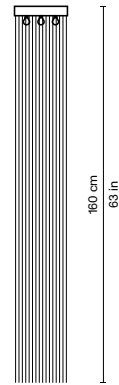
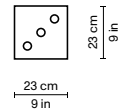

GARBO R

Designer:
Mariyo Yagi

Paradisoterrestre Edition 2017

First production:
Sirrah, 1973

Materials:
lacquered metal structure
and fabric fringes, 5 leds

Colours:
white ceiling lamp, white
fringe

W 112 | D 12 | H 160 or 300 cm
W 44,1 | D 4,7 | H 63 or 118,1 in

A light sparkling cascade, a transparent wall of wires, a translucent mirror moving with a breath of air, thus creating a bright sparkle, a magic presence in a space. Garbo may be used to divide rooms or to emphasize something exhibited.

Square-shaped ceiling element with applied white fabric fringe, easily removable, washable, heat-resistant and fire-proof. Heights are the following: 300 cm from the ceiling to the ground and 160 cm for table height. It is possible to cut off part of the fringe in order to reduce the height.

Applied both individually or side by side, with their casual and random placement, they live freely in the space. They are bright diaphragms separating an area without limiting it since you can cross them. Placed in front of a window they look like floating against the light.

The name Garbo was suggested by Dino Gavina as a tribute to the actress Greta Garbo, evidencing its unique beauty and elegance.

Garbo is part of the permanent collection of Tokyo National Museum of Modern Art and of La Galleria Nazionale in Rome.

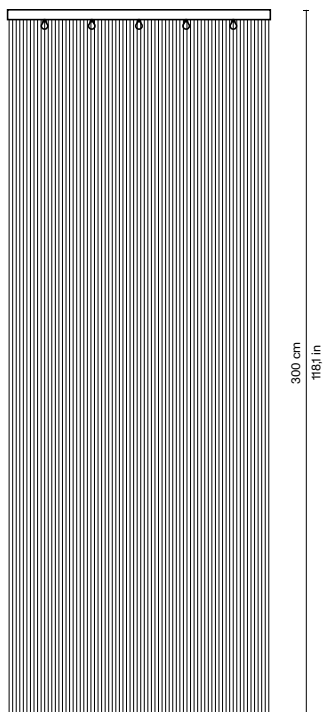
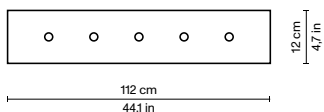
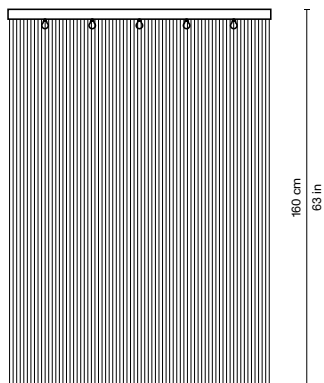
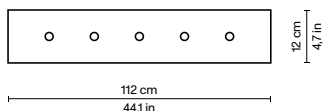

GARBO WAVE

Designer:	6 modules:
Mariyo Yagi	W 530, D 150 cm W 208,6, D 59 in max fringe height 70 cm
Paradisoterrestre Edition 2022	8 modules:
	W 730, D 150 cm W 287,4, D 59 in max fringe height 70 cm
Materials:	10 modules:
lacquered metal structure and fabric fringes	W 800, D 270 cm W 315, D 106,2 in max fringe height 70 cm
Colours:	
white ceiling lamp, white fringe	
	customizable number of modules, shape of curve and fringes height

Ceiling lamp composed of 6/8/10 curved modules and fringes designed to create a floating wave.

Available in two versions: classic with light bulbs or with opaque plexiglass ceiling element illuminated by dimmable leds.

A light sparkling cascade, a transparent wall of wires, a translucent mirror moving with a breath of air, thus creating a bright sparkle, a magic presence in a space. Garbo may be used to divide rooms or to emphasize something exhibited.

Wave-shaped ceiling element with applied white fabric fringe, easily removable, washable, heat-resistant and fire-proof. Customizable fringes height.

The name Garbo was suggested by Dino Gavina as a tribute to the actress Greta Garbo, evidencing its unique beauty and elegance.

Garbo is part of the permanent collection of Tokyo National Museum of Modern Art and of La Galleria Nazionale in Rome.

Garbo Wave's peculiar shape is inspired by the prototype realized by Japanese architect Kazuhide Takahama for his daughter Saori, adorning Paradisoterrestre gallery's ceiling since its opening in 2018.

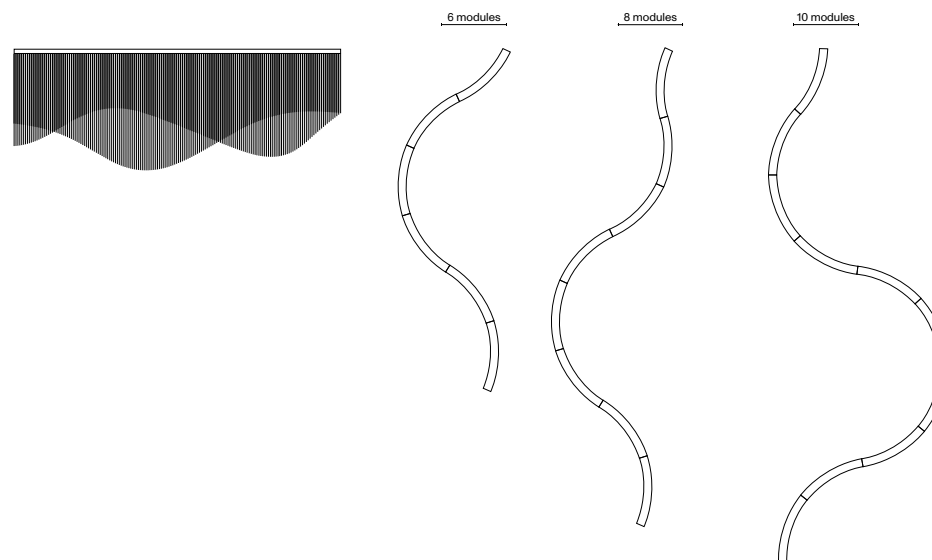

NOVELLO FINOTTI

(1939)

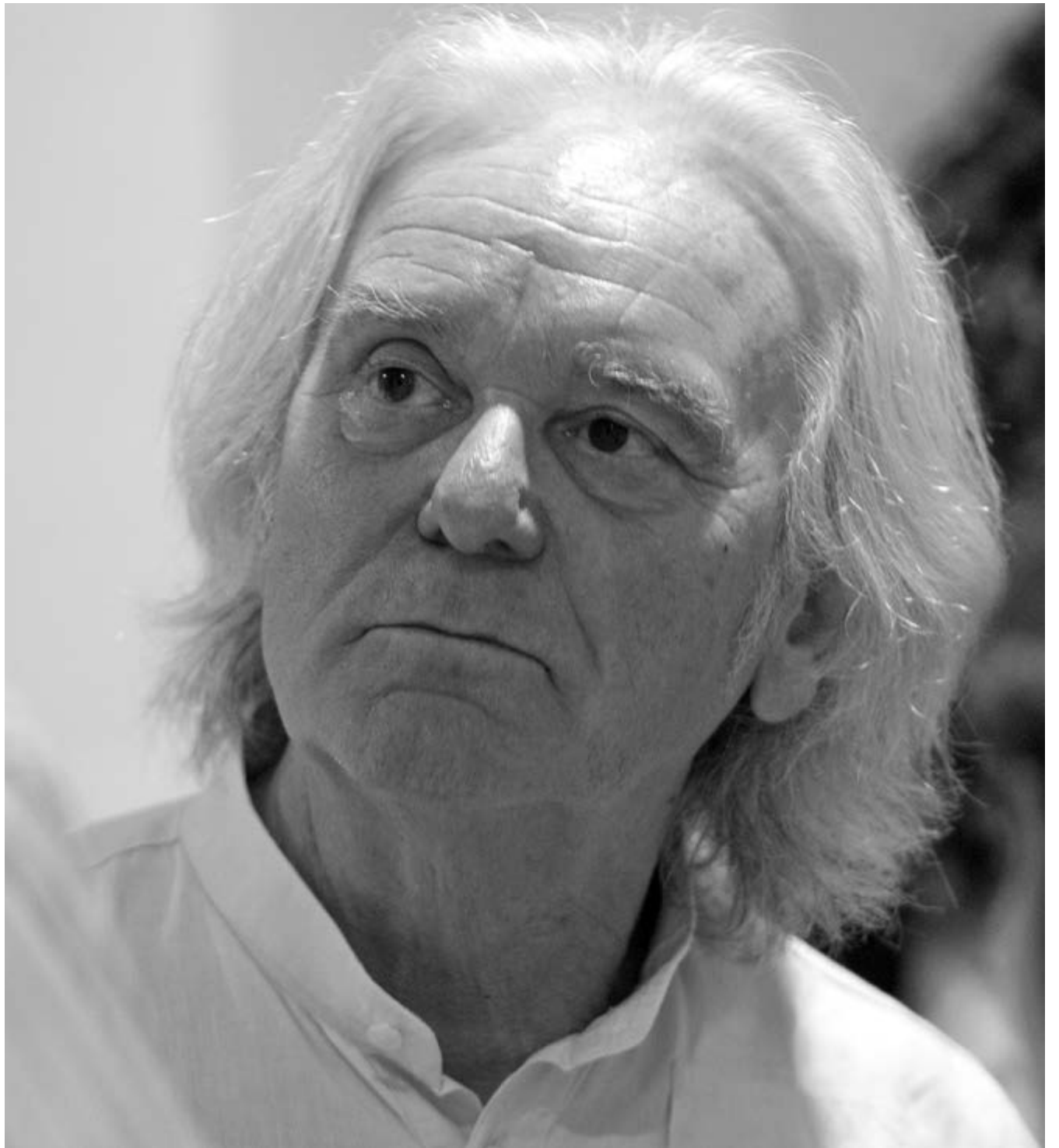

Italian sculptor who in his long career took part in important exhibitions in Italy and abroad. In 1972 Novello Finotti met Dino Gavina at his solo show at Alexander Iolas Gallery in Milan.

Born in Verona in 1939, Italian sculptor Novello Finotti lives and works between Sommacampagna (VR) and Pietrasanta (LU).

He was a student at Accademia Cignaroli and began exhibiting in 1958, winning a prize at the Exhibition of Sacred Art in Assisi. In 1964 he had a solo exhibition in New York at Armory Gallery. In 1966 he was invited to participate at XXXIII Venice Biennale. In 1972 at his solo show at Alexander Iolas Gallery in Milan he met Dino Gavina. In the same year he took part in the travelling exhibition *Scultori Italiani di Oggi* (Italian Sculptors of Today), curated by Professor Fortunato Bellonzi, exhibiting his works in Buenos Aires, Montevideo, Rio de Janeiro, San Paolo, Tokyo, Osaka, Hong Kong, East Berlin and Lugano. In 1976 he was invited to the Quadriennale in Rome and to the travelling exhibition *Il Bronzetto Italiano* (Italian Bronze Sculpture) in Finland, Denmark and Norway. He was in New York again in 1977 with a solo show at Iolas Jackson Gallery and in 1984 he was invited to exhibit at XLI Venice Biennale.

In 1986 a retrospective exhibition of his work was held at Palazzo Te, Mantova. In 1988-89 he took part with a set sculptures in marble in the travelling exhibition *La Scultura Italiana del XX Secolo* (Italian Sculpture in the 20th Century) in Japan, (The Museum of Fine Arts in Gifu, Art Museum in Niigata City, The Fukuyama Museum of Art). In 1990 he completed a monument to the poet Biagio Marin in Grado. In 1995 his solo show at Galleria del Credito Valtellinese, Refettorio delle Stelline in Milan. Between 1998 and 2001 he was commissioned to carry out various works including the re-working of the entire façade of the Basilica di S. Giustina in Padua. In 2001 he completed the gilded bronze decoration for the altar of Pope John XXIII in Saint Peter's Basilica in Vatican City. In 2002 he created a large-scale figure in white Carrara marble representing Saint Maria Soledad, positioned in one of the external niches of Saint Peter's Basilica in Vatican City. From 2002 to 2005 he had solo shows in Malcesine (VR), Galleria Forni in Milan, Sant'Anna di Stazzema (LU), and Abbazia di Rosazzo, Manzano (UD).

FAUSTO

NOVELLO
FINOTTI

1972



FAUSTO

Designer:
Novello Finotti

Materials:
polished cast bronze,
sheepskin fur

Paradisoterrestre Edition
2018

First production:
Simon International

– Ultramobile collection, 1972 W 30 | D 25 | H 48 cm
W 11,8 | D 9,8 | H 18,9 in

In Novello Finotti's fantastic world one has the insinuation of a throb of reality, a formidable impulse for the sculptor who tries to grasp and retain its sense, incorporating it in his world. "I have always used the body as a means of expression and in this work I have used the same concept".

Fausto, a small seat with a humanoid presence, represents in an exemplary way the concept of Ultramobile, the operation conceived by Dino Gavina in 1971, created with the aim of adapting a surrealist work to daily use object, maintaining a strong ironic charge to be transferred into the house.

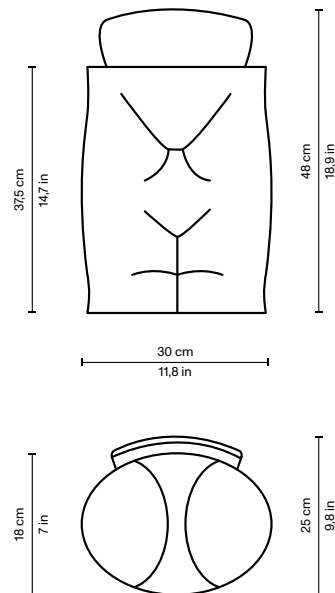

PAOLA PIVI

(1971)



Among the most important contemporary artists, with her sculptures, performance pieces and installation Paola Pivi builds a personal universe ruled by the laws of absurdity.

Paola Pivi was born in Milan in 1971. She lives and works between Anchorage, Alaska, and Val d'Aosta, Italy.

“With her sculptures, performance pieces and installations, Paola Pivi builds an upside-down world, a personal universe ruled by the laws of absurdity. The artist's work comes out of colossal undertakings, but is pervaded by lightness and irony: through changes of context, endless multiplications and radical displacements, Pivi's magical realism turns apparently impossible actions into disarmingly simple gestures” - Massimiliano Gioni, Artistic Director Fondazione Trussardi, Milan.

Pivi is the recipient of several awards including the Golden Lion at the 48th Venice Biennale for the best National Pavilion (together with other artists) and the fellowship at the American Academy in Rome in 2011.

Her works are present in prestigious permanent collections including Guggenheim Museum, New York, Centre Pompidou, Paris, Fondazione Sandretto Re Rebaudengo and Castello di Rivoli, Turin, MAXXI – Museo Nazionale delle Arti del XXI Secolo, Rome.

She has exhibited internationally at important museums and institutions including: Musée d'Art Moderne de la Ville de Paris (1999), PS.1 MoMA, New York (2000, 2001, 2003, 2007), MACRO, Rome (2003, 2010), Brown University, Providence (2004), MCA - Museum of Contemporary Art of Chicago (2005), CCA Wattis Institute for Contemporary Arts, San Francisco (2005), White Columns, New York (2005), MassArt - Massachusetts College of Art, Boston (2006), Hayward Gallery, London (2005), Fondazione Trussardi, Milan (2006), Kunsthalle Basel, Basel (2007), Portikus, Frankfurt (2008), Palazzo Grassi, Venice (2008), Tate Modern, London (2009), Schirn Kunsthalle, Frankfurt (2010), Rockbund Art Museum, Shanghai (2012), Dallas Contemporary, Dallas (2016), The Bass Museum of Art, Miami Beach (2018), Museo MAXXI, Rome (2019), Arken Museum of Modern Art, Copenhagen (2020).

In 2021 Paola Pivi creates exclusively for Paradisoterrestre the wall lamp Let'em shine art and the carpet Universe, presented for the first time in the exhibition Rock the art at Paradisoterrestre gallery.

LET'EM
SHINE ART

PAOLA PIVI

2021



LET'EM SHINE ART

Designer:
Paola Pivi

Paradisoterrestre Edition
2021

Materials:
fabric fringes, pvc bristles,
metal structure, led strip, 2
light bulbs

Colours:
red, blue, brown

W 35 | D 60 | H 200 cm
W 13,8 | D 23,6 | H 78,7 in

Paola Pivi creates exclusively for Paradisoterrestre Let'em shine art, presented for the first time in the exhibition "Rock the art" at Paradisoterrestre Gallery.

Let'em shine art is a limited edition wall lamp, a tribute to Garbo by Japanese artist Mariyo Yagi and to Italian artist Pino Pascali's Bachi da setola.

Let'em shine art allows to create different atmospheres thanks to the various combinations of the three light sources: a led strip that runs along the perimeter of the bristle and two light bulbs in the center of the fringes, one at the top and one at the bottom.

Limited edition of 50 for each colour.

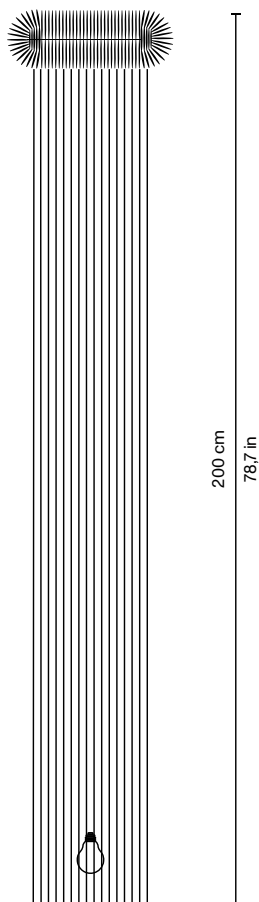
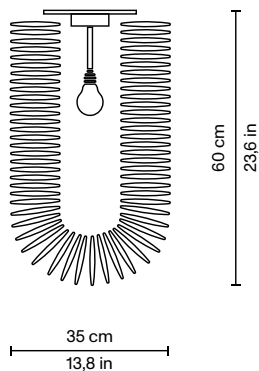

UNIVERSE

PAOLA PIVI

2021



UNIVERSE

Designer:
Paola Pivi

Materials:
wool and bamboo silk

Paradisoterrestre Edition
2021

W 287 | D 200 cm
W 113 | D 78,7 in

Paola Pivi creates exclusively for Paradisoterrestre Universe, presented for the first time in the exhibition Rock the art at Paradisoterrestre gallery.

Universe is a limited edition carpet inspired by her early work Untitled (1998), created from the invitation for her first solo exhibition at Massimo De Carlo Gallery in Milan in 1998.

Limited edition of 12 pieces.

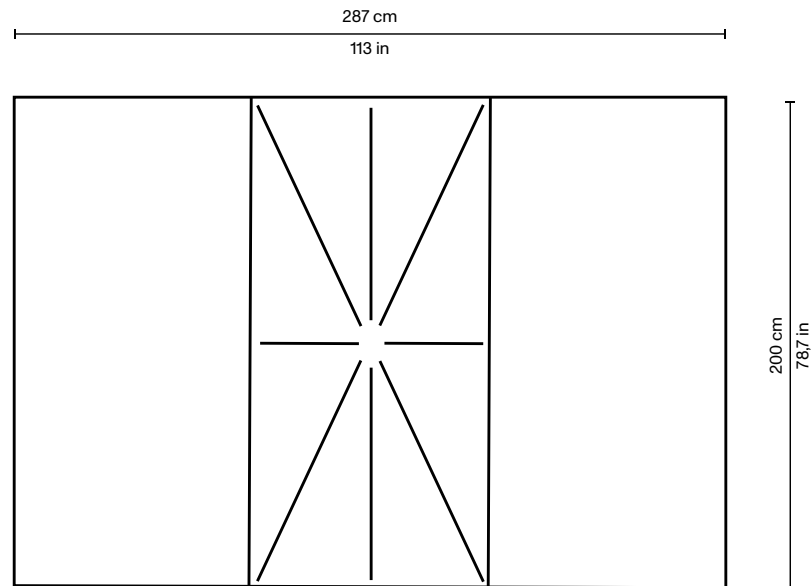
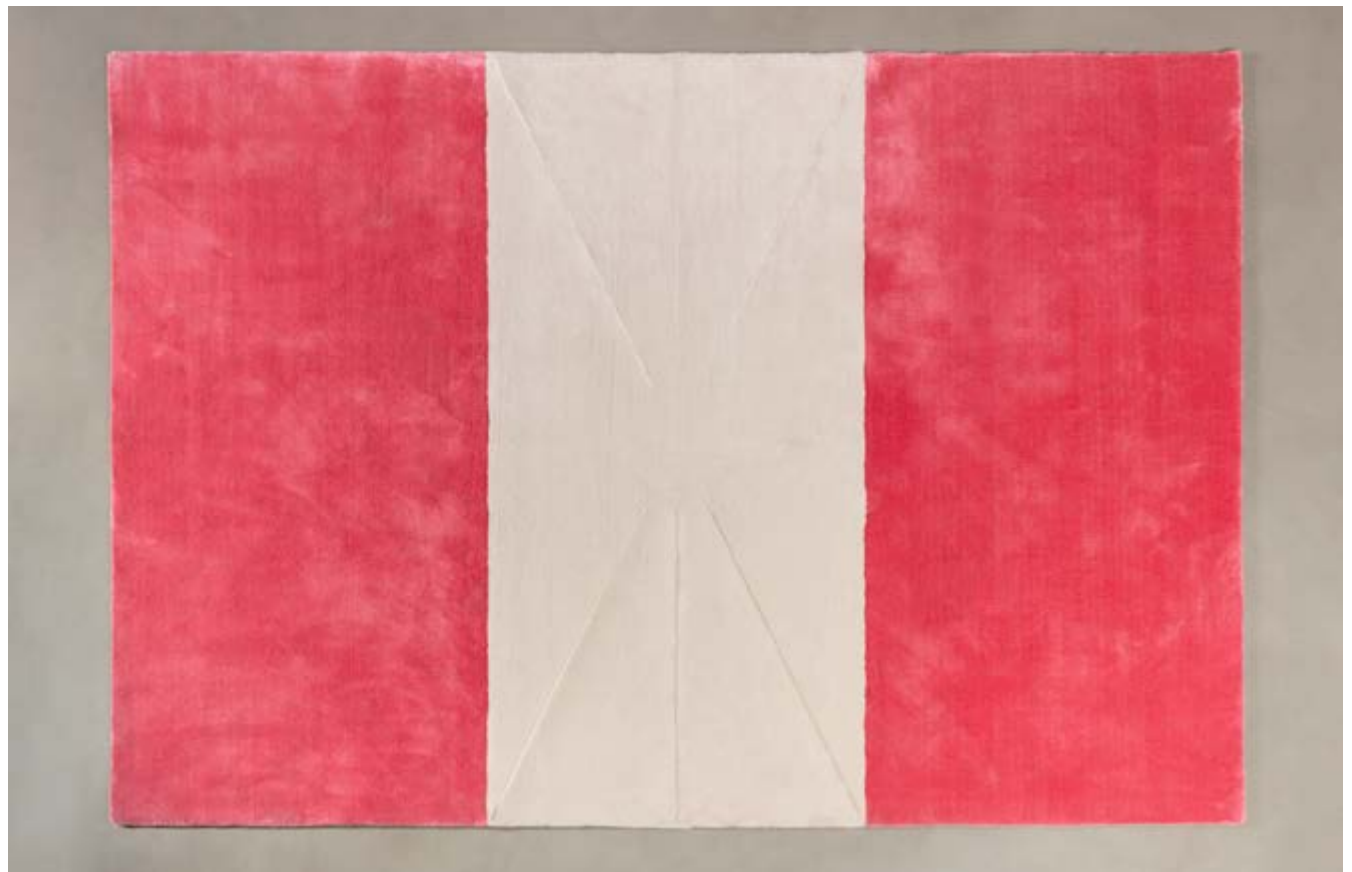

PIERRE GONALONS

(1977)

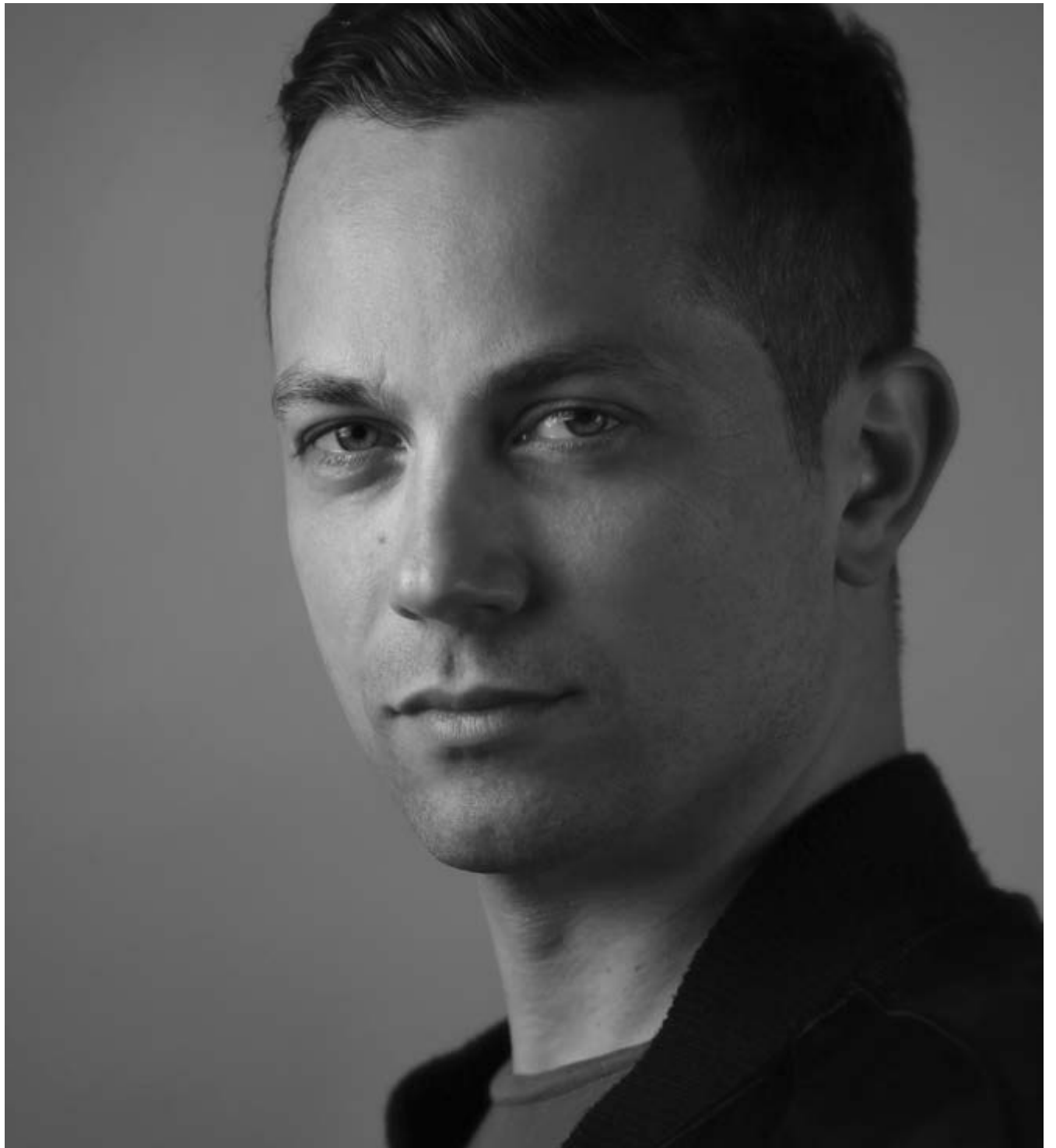

Among AD top 100 designers, Pierre Gonalons is establishing himself on the international scene with his unique vision of design and space, imbued with references to pop culture and decorative arts.

Pierre Gonalons is a designer and interior architect based in Paris. Born in Lyon in 1977 in a family of Italian background, he very early on develops a pronounced taste for art history as well as French cultural heritage.

After graduating from École Camondo in Paris, he quickly sets the tone for his singular take on design and space. He founded his own creative studio at the age of 23 and collaborates with prestigious brands such as Lalique, Chloé, Pierre Frey, Nina Ricci, Pernod, Weston... while simultaneously developing his very own limited edition line of products for international galleries.

Drawing inspiration from a long history of craftsmanship of traditional materials, his creations come across as both simple and spectacular dialogues between present and past. He defends a minimalist approach of design imbued with references to pop culture and decorative arts. Since 2016 Pierre Gonalons has been focusing his creativity on a wide array of interior architecture projects. In the pure tradition of the greatest holistic interior architects, and fueled by his own experience in furniture design, he takes at heart to draw every single detail of his decors, down to the finest element. In 2019 he took part in the prestigious AD Intérieurs exhibition and is awarded AD top 100 designers.

Widely covered by international press, his work has lately been featured in numerous in depth articles by magazines such as AD, Elle décoration, Interni, Icon design and Departure.

A great admirer of Dino Gavina, Pierre Gonalons has been collaborating on a permanent basis with Paradisoterrestre since the relaunch of the brand: in addition to having designed three collections – The Other Side (2017), All Around (2018) and See Through (2019/20) – and two fabrics Fiori (2017) and Futuristi (2018), he is creative director of Paradisoterrestre gallery in Bologna.

THE OTHER SIDE

PIERRE
GONALONS

2017

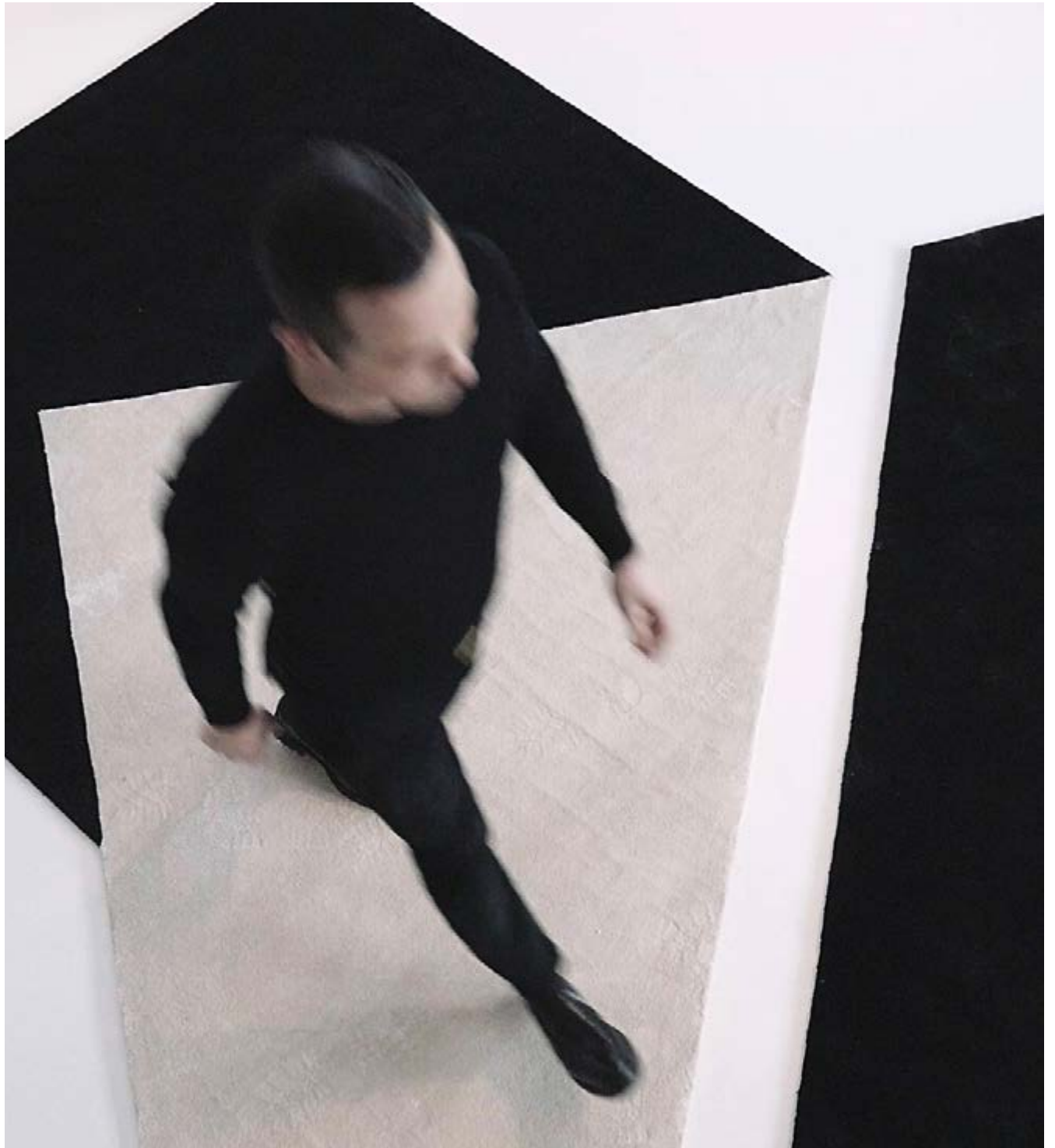

THE OTHER SIDE COFFEE TABLE

Designer:
Pierre Gonalons

Colours:
green and black. Also
available in white and black

Paradisoterrestre Edition 2017

Materials:
French marble green "Vert
d'Estours" and black "Petit
Antique"

W 87 | D 60 | H 40 cm
W 34,2 | D 23,6 | H 15,7 in

For Paradisoterrestre Pierre Gonalons designed The Other Side collection inspired by the pleat, the reverse of things, the verso which is usually hidden, a symbolic and poetic concept that takes us beyond the form. It speaks about Italian Baroque, illusion, Surrealism but also about the fold as a metaphor of the soul, like Deleuze described it.

For the marble furniture The Other Side, Pierre Gonalons has used French marbles extracted from two quarries of the Pyrenees since antiquity: "Vert d'Estours" and "Petit Antique".

Limited edition of 12.

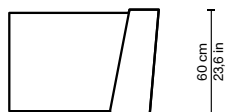
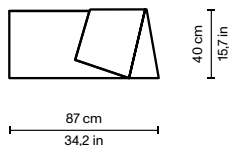

THE OTHER SIDE SIDE TABLE

Designer:
Pierre Gonalons

Colours:
green and black. Also
available in white and black

Paradisoterrestre Edition 2017

Materials:
French marble green "Vert
d'Estours" and black "Petit
Antique"

W 65 | D 50 | H 50 cm
W 25,6 | D 19,7 | H 19,7 in

For Paradisoterrestre Pierre Gonalons designed The Other Side collection inspired by the pleat, the reverse of things, the verso which is usually hidden, a symbolic and poetic concept that takes us beyond the form. It speaks about Italian Baroque, illusion, Surrealism but also about the fold as a metaphor of the soul, like Deleuze described it.

For the marble furniture The Other Side, Pierre Gonalons has used French marbles extracted from two quarries of the Pyrenees since antiquity: "Vert d'Estours" and "Petit Antique".

Limited edition of 12.

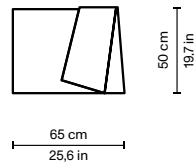

THE OTHER SIDE CONSOLE

Designer:
Pierre Gonalons

Colours:
green and black. Also
available in white and black

Paradisoterrestre Edition 2017

Materials:
French marble green "Vert
d'Estours" and black "Petit
Antique"

W 116 | D 40 | H 90 cm
W 45,7 | D 15,7 | H 35,4 in

For Paradisoterrestre Pierre Gonalons designed The Other Side collection inspired by the pleat, the reverse of things, the verso which is usually hidden, a symbolic and poetic concept that takes us beyond the form. It speaks about Italian Baroque, illusion, Surrealism but also about the fold as a metaphor of the soul, like Deleuze described it.

For the marble furniture The Other Side, Pierre Gonalons has used French marbles extracted from two quarries of the Pyrenees since antiquity: "Vert d'Estours" and "Petit Antique".

Limited edition of 12.

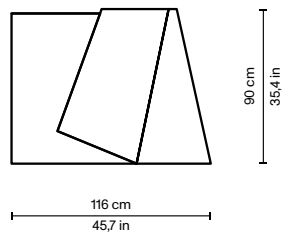

THE OTHER SIDE CARPET 1

Designer:
Pierre Gonalons

Materials:
wool and bamboo silk

Paradisoterrestre Edition 2017 Colours:
black and white or white and
blue

W 287 | D 226 cm
W 113 | D 88,9 in

For Paradisoterrestre Pierre Gonalons designed The Other Side collection inspired by the pleat, the reverse of things, the verso which is usually hidden, a symbolic and poetic concept that takes us beyond the form. It speaks about Italian Baroque, illusion, Surrealism but also about the fold as a metaphor of the soul, like Deleuze described it.

The carpet collection The Other Side is produced in a limited edition of 30 for each variant.

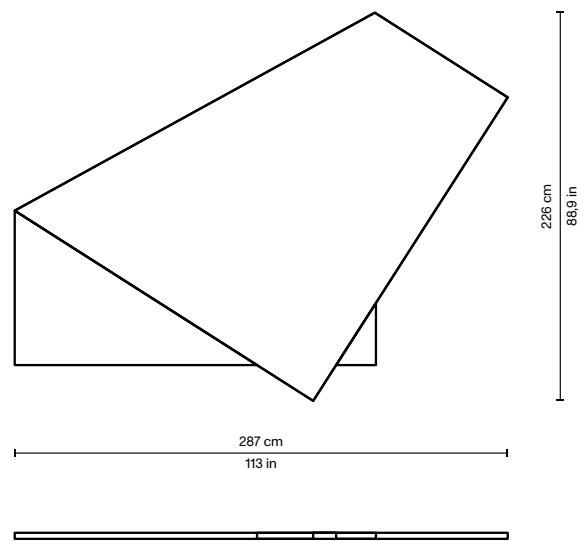

THE OTHER SIDE CARPET 2

Designer:
Pierre Gonalons

Materials:
wool and bamboo silk

Paradisoterrestre Edition 2017 Colours:
black and white or black and
green

W 293 | D 270 cm
W 115,3 | D 106,3 in

For Paradisoterrestre Pierre Gonalons designed The Other Side collection inspired by the pleat, the reverse of things, the verso which is usually hidden, a symbolic and poetic concept that takes us beyond the form. It speaks about Italian Baroque, illusion, Surrealism but also about the fold as a metaphor of the soul, like Deleuze described it.

The carpet collection The Other Side is produced in a limited edition of 30 for each variant.

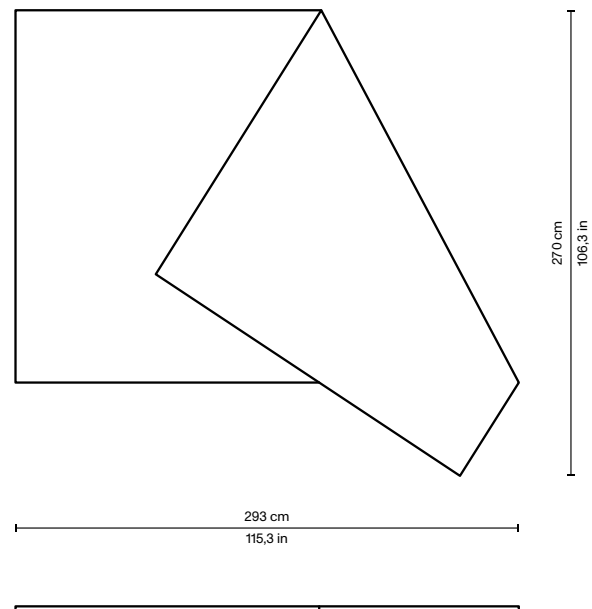

ALL AROUND

PIERRE
GONALONS

2018

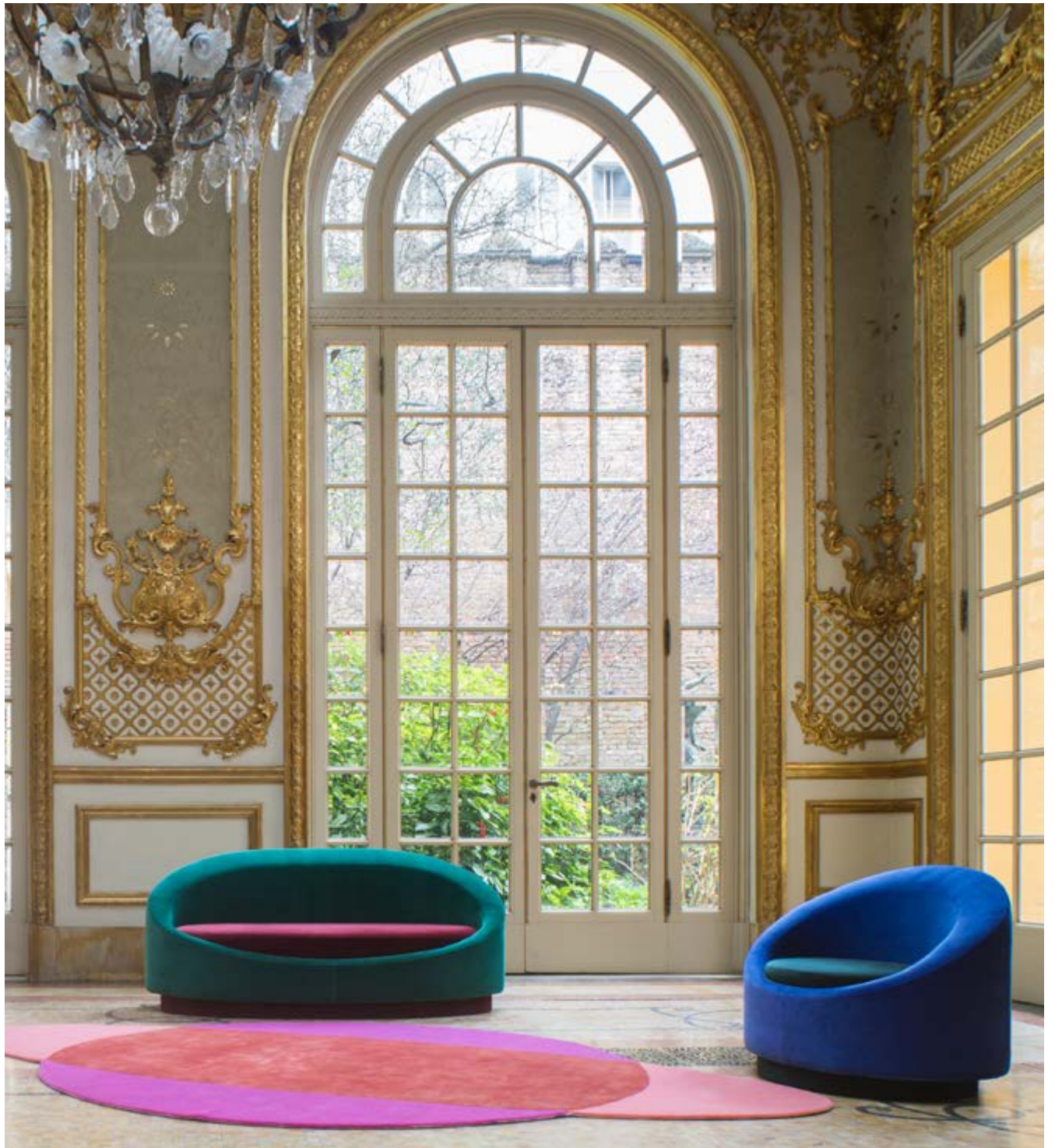

ALL AROUND CHAIR

Designer:
Pierre Gonalons

Paradisoterrestre Edition
2018

Materials:
plywood base and back,
polyurethane foam structure.
Upholstery available in diffe-
rent fabrics

W 60 | D 54 | H 73,5 cm
W 23,6 | D 21,2 | H 28,9 in

"After The Other Side, my first collection for Paradisoterrestre in 2017, I wanted to give continuity and shape to this poetic design concept in 2018 with All Around collection.

This title suggests that we should look beyond an idea or a creation instead of being focused on the topic and on the result, maybe some interesting things could happen in between. It means that after having looked below, we have to look around.

I took inspiration from the revolutionary creations of designer Kazuhide Takahama for Dino Gavina. His sofa concepts were simple, innovative, beautiful, and I just tried to apply his lesson. It's also a wink to the city of Bologna, with the thousands of columns along its streets."

– Pierre Gonalons

Available also in the rotating version.

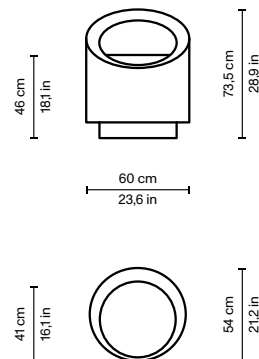

ALL AROUND ARMCHAIR

Designer:
Pierre Gonalons

Paradisoterrestre Edition
2018

Materials:
plywood base and back,
polyurethane foam structure.
Upholstery available in diffe-
rent fabrics

W 86 | D 66 | H 70 cm
W 33,8 | D 26 | H 27,5 in

"After The Other Side, my first collection for Paradisoterrestre in 2017, I wanted to give continuity and shape to this poetic design concept in 2018 with All Around collection.

This title suggests that we should look beyond an idea or a creation instead of being focused on the topic and on the result, maybe some interesting things could happen in between. It means that after having looked below, we have to look around.

I took inspiration from the revolutionary creations of designer Kazuhide Takahama for Dino Gavina. His sofa concepts were simple, innovative, beautiful, and I just tried to apply his lesson. It's also a wink to the city of Bologna, with the thousands of columns along its streets."

– Pierre Gonalons

Available also in the rotating version.

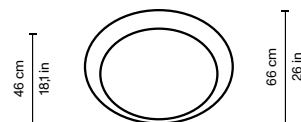
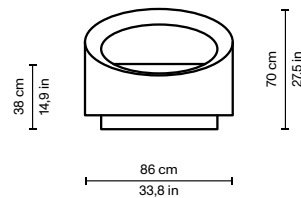

ALL AROUND SOFA 160

Designer:
Pierre Gonalons

Paradisoterrestre Edition
2018

Materials:
plywood base and back,
polyurethane foam structure.
Upholstery available in diffe-
rent fabrics

W 160 | D 70 | H 70 cm
W 63 | D 27,5 | H 27,5 in

"After The Other Side, my first collection for Paradisoterrestre in 2017, I wanted to give continuity and shape to this poetic design concept in 2018 with All Around collection.

This title suggests that we should look beyond an idea or a creation instead of being focused on the topic and on the result, maybe some interesting things could happen in between. It means that after having looked below, we have to look around.

I took inspiration from the revolutionary creations of designer Kazuhide Takahama for Dino Gavina. His sofa concepts were simple, innovative, beautiful, and I just tried to apply his lesson. It's also a wink to the city of Bologna, with the thousands of columns along its streets."

– Pierre Gonalons

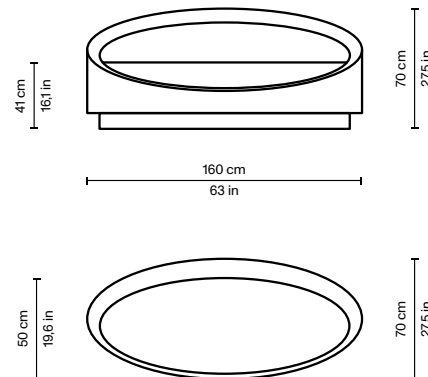

ALL AROUND SOFA 220

Designer:
Pierre Gonalons

Paradisoterrestre Edition
2018

Materials:
plywood base and back,
polyurethane foam structure.
Upholstery available in diffe-
rent fabrics

W 220 | D 75 | H 70 cm
W 86,6 | D 29,5 | H 27,5 in

"After The Other Side, my first collection for Paradisoterrestre in 2017, I wanted to give continuity and shape to this poetic design concept in 2018 with All Around collection.

This title suggests that we should look beyond an idea or a creation instead of being focused on the topic and on the result, maybe some interesting things could happen in between. It means that after having looked below, we have to look around.

I took inspiration from the revolutionary creations of designer Kazuhide Takahama for Dino Gavina. His sofa concepts were simple, innovative, beautiful, and I just tried to apply his lesson. It's also a wink to the city of Bologna, with the thousands of columns along its streets."

– Pierre Gonalons

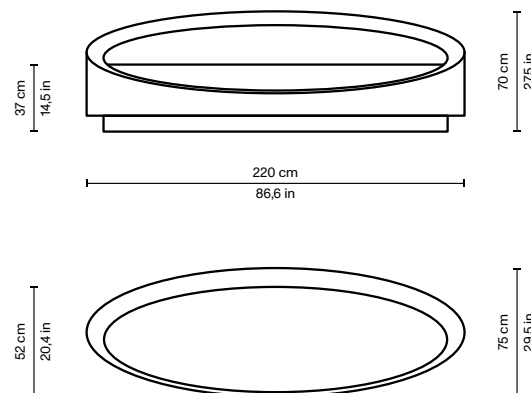

ALL AROUND CARPET

Designer:
Pierre Gonalons

Materials:
wool and bamboo silk

Paradisoterrestre Edition
2018

Colours:
shades of blue, shades of pink,
shades of green

W 300 | D 200 cm
W 118,1 | D 78,4 in

"After The Other Side, my first collection for Paradisoterrestre in 2017, I wanted to give continuity and shape to this poetic design concept in 2018 with All Around collection.

This title suggests that we should look beyond an idea or a creation instead of being focused on the topic and on the result, maybe some interesting things could happen in between. It means that after having looked below, we have to look around.

– Pierre Gonalons

This carpet is a new proposal for a non-square shaped rug. After The Other Side and its pleat, All Around Carpet is an optical game. It plays with colors between the round and the oval. It is also a tribute to Dino Gavina's production in the 70s, between Surrealism and Pop Art.

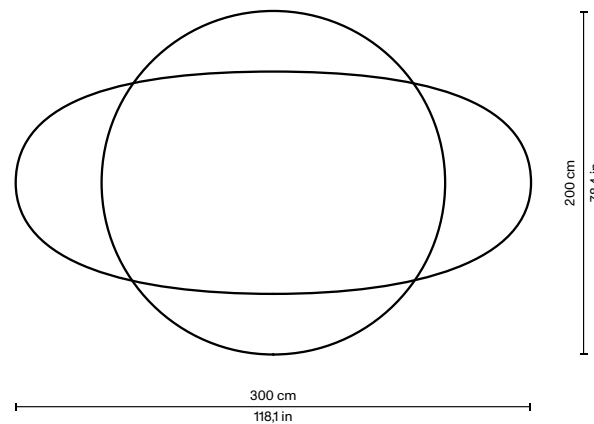
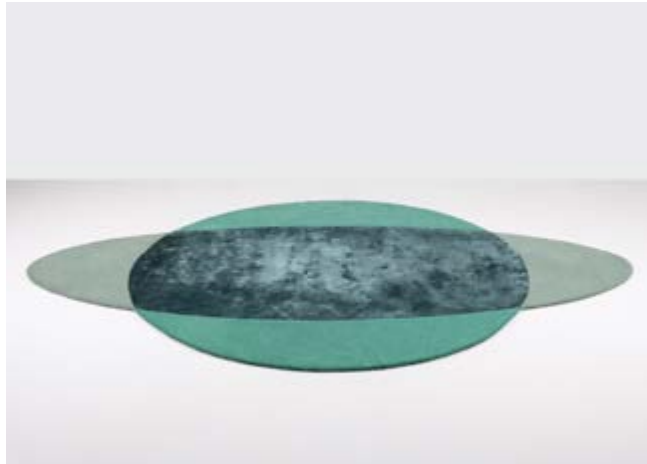

SEE THROUGH

PIERRE
GONALONS

2019/20



SEE THROUGH ARMCHAIR

Designer:
Pierre Gonalons

Paradisoterrestre Edition
2019

Materials:
multilayer and solid fir wood
structure, polyurethane foam

Available finishes: satin brass
bands and varnished metal
feet or brushed steel bands
and aluminum feet. Uphol-
stery available in different
fabrics

W 82 | D 76 | H 74 cm
W 32,3 | D 29,9 | H 29,1 in

After the collections The Other Side (2017) and All Around (2018), See Through is the new collection designed by Pierre Gonalons for Paradisoterrestre.

“Inspired by Paradisoterrestre conceptual spirit, See Through revisits the 70’s mood. A cube characterized by round openings on three sides, which transports us in time and space: perfect in a luxury hotel in Monaco or in a jazz club in Tokyo.”

-Pierre Gonalons

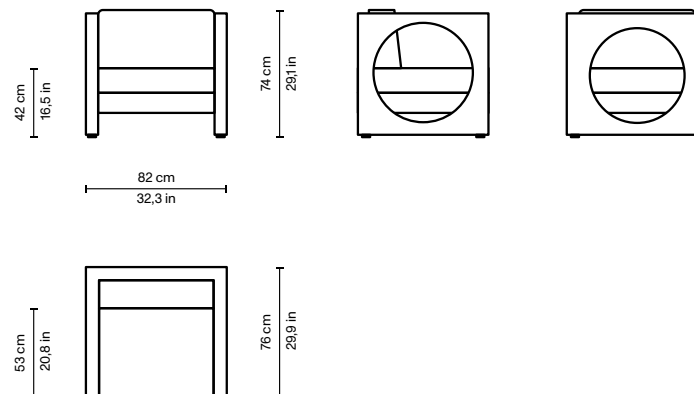

SEE THROUGH SOFA 152

Designer:
Pierre Gonalons

Paradisoterrestre Edition
2020

Materials:
multilayer and solid fir wood
structure, polyurethane foam

Available finishes: satin brass
bands and varnished metal
feet or brushed steel bands
and aluminum feet. Uphol-
stery available in different
fabrics

W 152 | D 76 | H 74 cm
W 59,8 | D 29,9 | H 29,1 in

After The Other Side (2017) and All Around (2018), See Through is the new collection designed by Pierre Gonalons for Paradisoterrestre.

“Inspired by Paradisoterrestre conceptual spirit, See Through revisits the 70’s mood. A two-seater sofa characterized by round openings on three sides, which transports us in time and space: perfect in a luxury hotel in Monaco or in a jazz club in Tokyo.”

-Pierre Gonalons

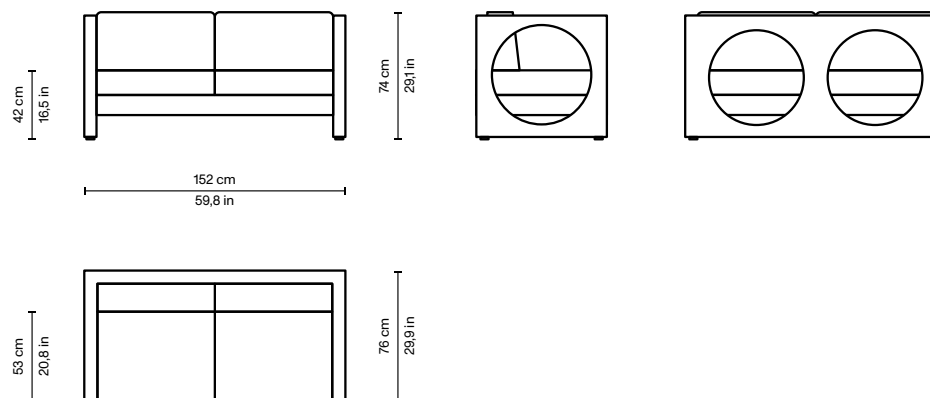

SEE THROUGH SOFA 222

Designer:
Pierre Gonalons

Paradisoterrestre Edition
2020

Materials:
multilayer and solid fir wood
structure, polyurethane foam

Available finishes: satin brass
bands and varnished metal
feet or brushed steel bands
and aluminum feet. Uphol-
stery available in different
fabrics

W 222 | D 76 | H 74 cm
W 87,4 | D 29,9 | H 29,1 in

After The Other Side (2017) and All Around (2018), See Through is the new collection designed by Pierre Gonalons for Paradisoterrestre.

“Inspired by Paradisoterrestre conceptual spirit, See Through revisits the 70’s mood. A three-seater sofa characterized by round openings on three sides, which transports us in time and space: perfect in a luxury hotel in Monaco or in a jazz club in Tokyo.”

-Pierre Gonalons

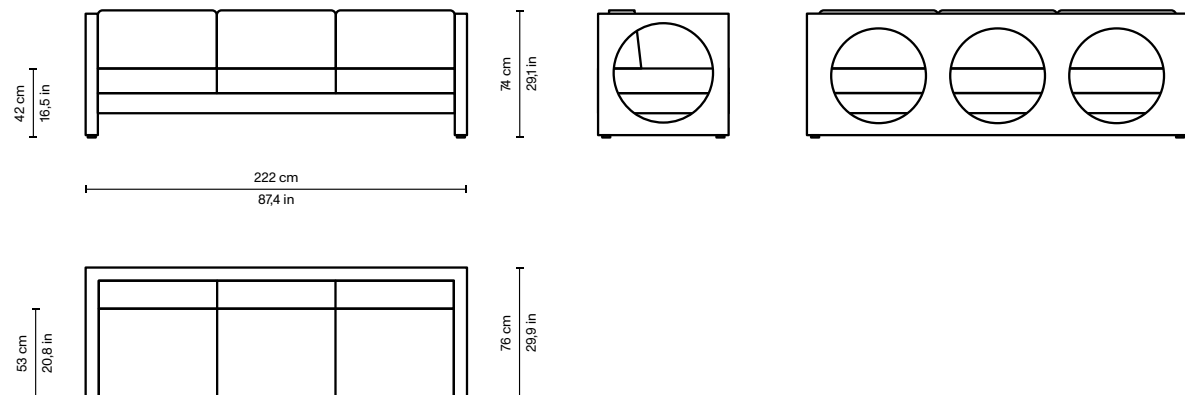

ROBERTO MATTA

(1911 – 2002)

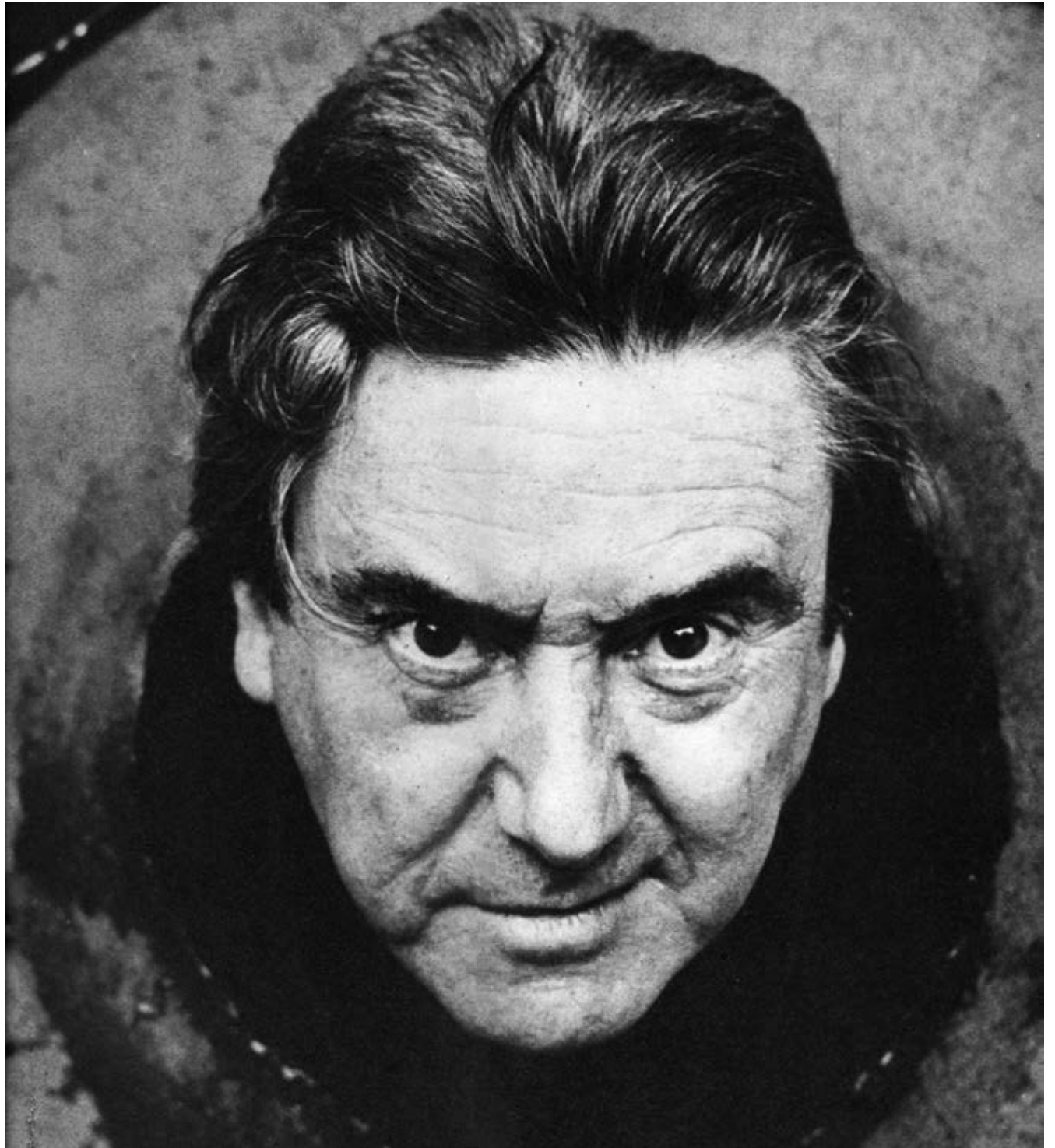

Seminal figure of the Surrealist Movement and mentor of various exponents of Abstract Expressionism, Roberto Matta is considered one of the most interesting artists of 20th century, with his production between art and design.

Roberto Sebastián Antonio Matta Echaurren was born in Santiago, Chile where he studied architecture.

In 1934 he moved to Paris to work as an apprentice to the architect Le Corbusier. He met Salvador Dalí and André Breton and left Le Corbusier's atelier to join the Surrealist movement. In 1939 together with André Breton, Max Ernst, Yves Tanguy and other Surrealist artists he moved to New York. During the '40s Matta's painting anticipated many innovations of the Abstract expressionists and influenced different artists of the so-called New York School and in particular Gorky and Motherwell. He broke with the Surrealists in 1948 and returned to Europe, settling in Rome in 1953. In the late '50s Matta was an internationally renowned artist, with works exhibited in important museums in London, New York, Venice, Chicago, Rome, Washington and Paris.

In the mid-'60s, he started a collaboration with Dino Gavina that led to the creation of iconic design pieces such as Malitte (1966) and for the Ultramobile collection (1971) Margarita, Sacco Alato and MAgriTTA.

Among his most important exhibitions, the major retrospectives held at MoMA in New York in 1957 and at Centre Pompidou in Paris in 1985.

MALITTE

ROBERTO MATTA

1966



MALITTE

Designer:
Roberto Matta

Materials:
polyurethane foam. Uphol-
stery available in different
fabrics

Paradisoterrestre Edition
2019

First productions:
Gavina (1966 – 1968),
Knoll International (1968 –
1974)

W 160 | D 63 | H 160 cm
W 63 | D 24,8 | H 63 in

Malitte is a seating system, an ever-changing composition of five polyurethane blocks.

A playful collection of colored interlocking organic shapes that can be assembled into a single sculpture, a “wall” dividing the environment with its formal and conceptual presence, which, when necessary, can instantly become a complete living room: a two-seater sofa, three seats and a pouf.

Malitte is part of the permanent collection of MoMA – the Museum of Modern Art in New York City and of La Galleria Nazionale in Rome.

Malitte is available also in a brand-new outdoor version made of polyurethane for outdoor use and water-oil repellent resistant to UVA rays fabrics.

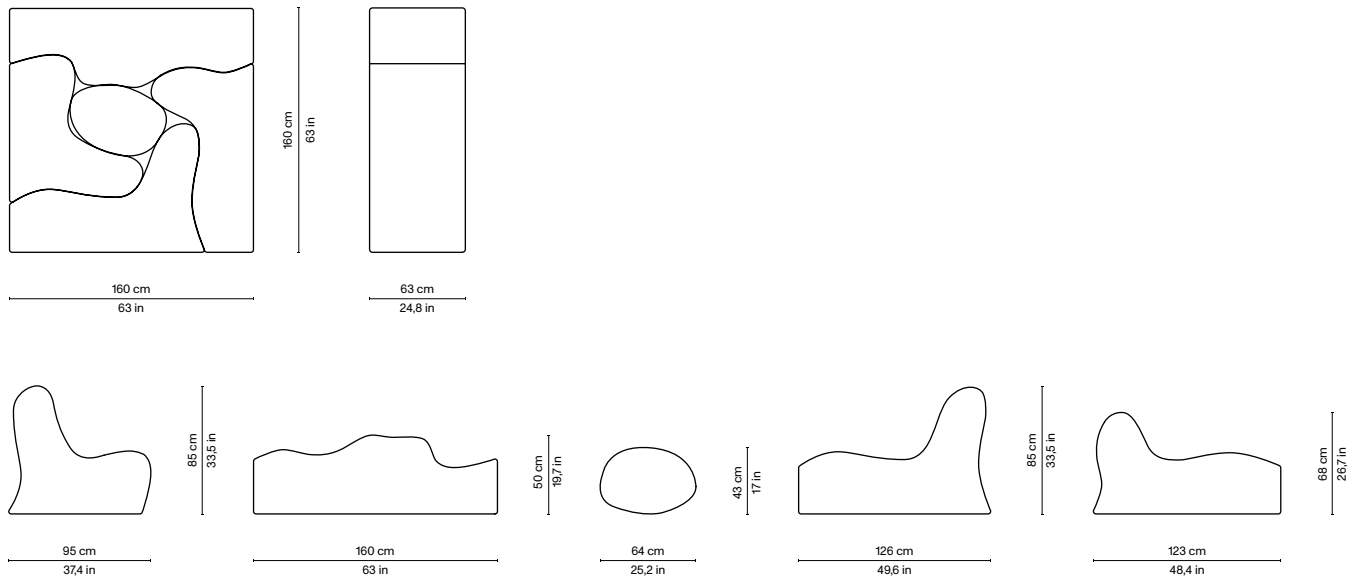

MARGARITA

ROBERTO MATTA

1971



MARGARITA

Designer:
Roberto Matta

Bronze:
86 kg | 190 lb

Paradisoterrestre Edition
2019

Aluminium:
28 kg | 62 lb

First production:
Simon International
– Ultramobile collection, 1971

Materials:
cast bronze or cast
aluminium

W 88 | D 48 | H 135 cm
W 34,6 | D 18,9 | H 53,1 in

This “functional work of art” represents in an exemplary way the concept of Ultramobile, operation conceived by Dino Gavina in 1971 with the aim of adapting in a surprising way the surrealist object to daily use. Margarita was cast in bronze the first time to fix an idea: it is a petrol can, opened up like a daisy, a barrel turned into a tribal throne.

Almost 50 years after the first prototypes and the very few works produced by Simon International, the re-edition of Margarita in the historical bronze version and in a brand new aluminium version has been possible thanks to Alisée Matta.

Limited edition of 25 pieces for each variant, with engraved identification number and artist’s signature. Each piece is accompanied by a Certificate of Authenticity.

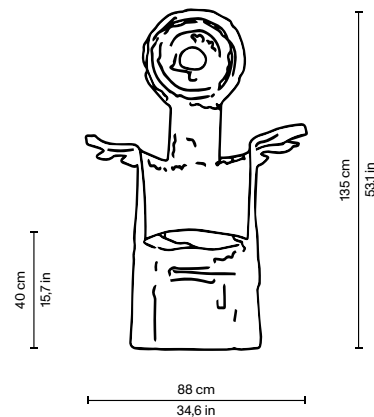

SACCO ALATO

ROBERTO MATTA

1971

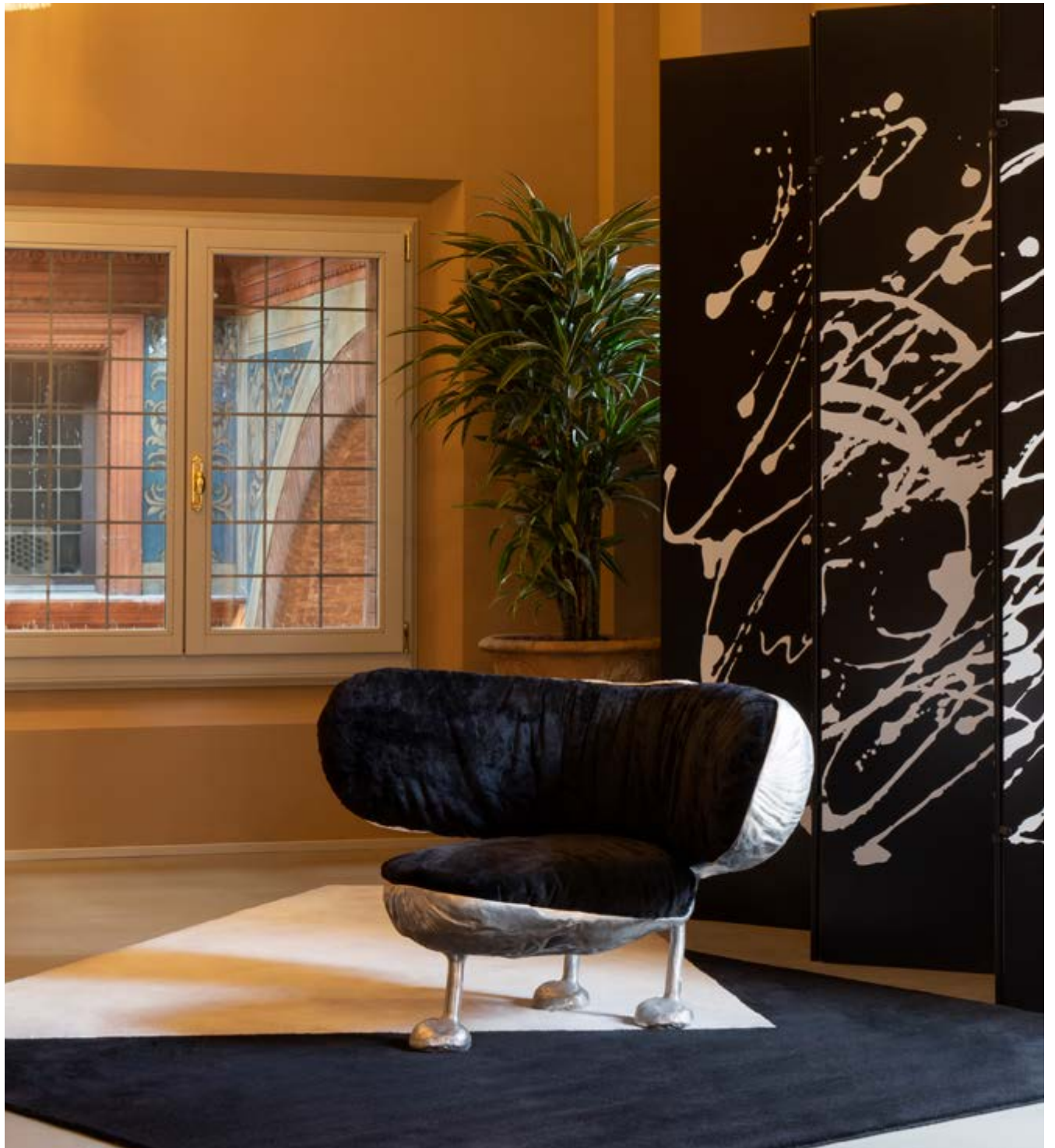

SACCO ALATO

Designer:
Roberto Matta

Bronze:
60 kg | 132 lb

Paradisoterrestre Edition
2019

Aluminium:
20 kg | 44 lb

First production:
Simon International
– Ultramobile collection, 1971

Materials:

cast bronze or cast aluminium, polyurethane foam covered with chenille velvet

W 125 | D 80 | H 67 cm
W 49,2 | D 31,5 | H 26,4 in

This “functional work of art” represents in an exemplary way the concept of Ultramobile, operation conceived by Dino Gavina in 1971 with the aim of adapting in a surprising way the surrealist object to daily use. Sacco Alato was born in foundry while making Margarita, casting a bag of concrete and splitting it in two. Lacking any other props, the big road rocks provided the feet for this seat/sculpture.

Almost 50 years after the first prototypes and the very few works produced by Simon International, the re-edition of Sacco Alato in the historical bronze version and in a brand new aluminium version has been possible thanks to Alisée Matta.

Limited edition of 25 pieces for each variant, with engraved identification number and artist’s signature. Each piece is accompanied by a Certificate of Authenticity.

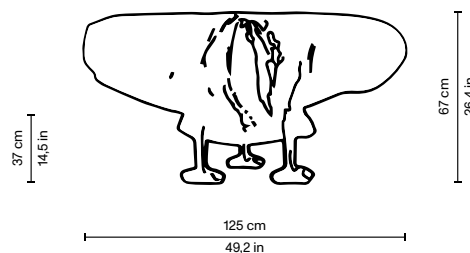

AMATTA

ROBERTO MATTA

1974



AMATTA

Designer:
Roberto Matta

Materials: resin

Paradisoterrestre Edition
2024

First production: 1974

W 110 | D 100 | H 130 cm
W 43,3 | D 39,4 | H 51,8 in

Amatta is a resin armchair with sinuous, fluid, soft and rounded lines, created in 1974 by Roberto Matta.

He cuddled up in the Amatta and shaped it through his own body.

The armchair was never put into production, only three prototypes were made. An unfinished project that Paradisoterrestre, 50 years later, brings back to life.

Limited edition of 1000 with engraved identification number and artist's signature.

Paradisoterrestre Edition from 2/1000 to 30/1000, courtesy of Alis e Matta's share.

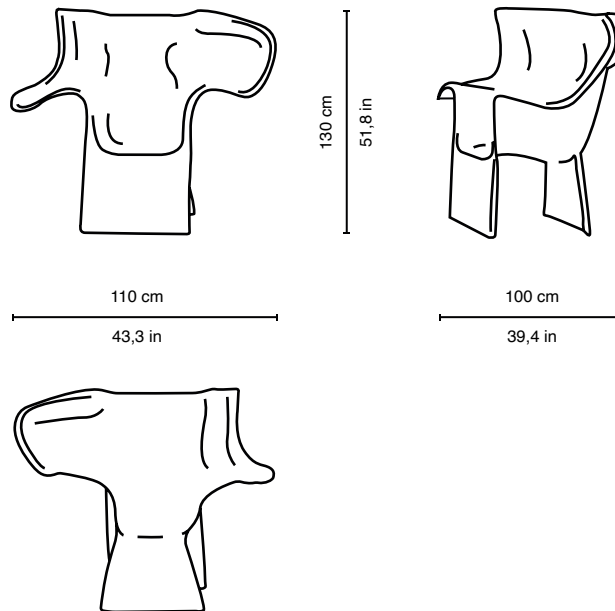

ORE TRE

ROBERTO MATTA

EARLY 1970s



ORE TRE

Designer:
Roberto Matta

Materials: aluminium, pvc
shade, plexiglass base

Paradisoterrestre Edition
2026

Ø 26 H 69 cm
Ø 10,2 H 27,2 in

First production: Early 1970s

Born in the early 1970s from the multifaceted imagination of surrealist artist Roberto Matta and designed for the intimacy of his home, Ore Tre is an aluminium table lamp with a PVC shade and a plexiglass base, a light sculpture that illuminates your room.

The re-edition of Ore Tre, made possible thanks to Alisée Matta, is produced in collaboration with Fonderia Artistica Flli Bonvicini, a historic company with which the artist had often worked.

Limited edition of 25 pieces, with engraved identification number and artist's signature. Each piece is accompanied by a Certificate of Authenticity.

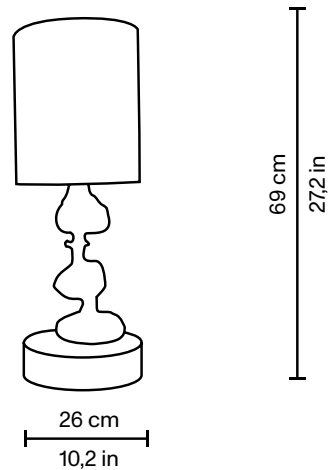

MEZZANOTTE

ROBERTO MATTA

EARLY 1970s

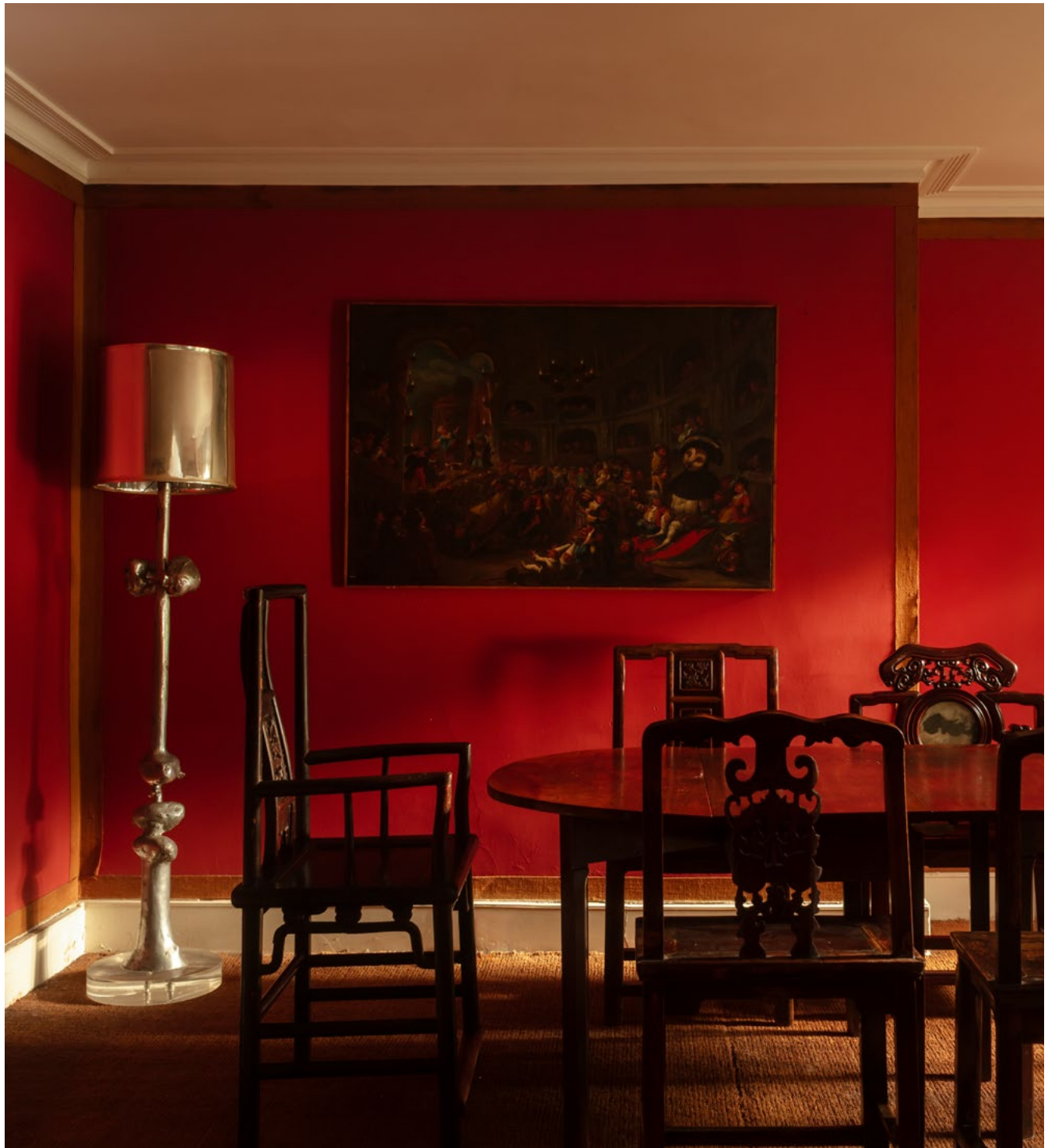

MEZZANOTTE

Designer:
Roberto Matta

Materials: aluminium, pvc
shade, plexiglass base

Paradisoterrestre Edition
2026

Ø 38 H 171 cm
Ø 15 H 67,3 in

First production: Early 1970s

Born in the early 1970s from the multifaceted imagination of surrealist artist Roberto Matta and designed for the intimacy of his home, Mezzanotte is an aluminium floor lamp with a PVC shade and a plexiglass base, a light sculpture that illuminates your room.

The re-edition of Mezzanotte, made possible thanks to Alisée Matta, is produced in collaboration with Fonderia Artistica Flli Bonvicini, a historic company with which the artist had often worked.

Limited edition of 25 pieces, with engraved identification number and artist's signature. Each piece is accompanied by a Certificate of Authenticity.

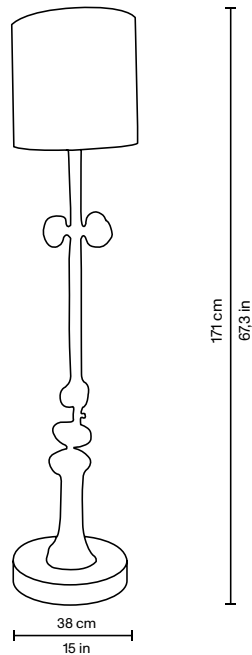

ROMBO

ROBERTO MATTA

EARLY 1970s



ROMBO

Designer:
Roberto Matta

Materials: gold-lacquered
metal, fabric lampshade

Paradisoterrestre Edition
2026

Ø 40 H 184 cm
Ø 15,7 H 72,4 in

First production: Early 1970s

Born in the early 1970s from the multifaceted imagination of surrealist artist Roberto Matta and designed for the intimacy of his home, Rombo is a handcrafted gold-lacquered metal floor lamp with a fabric lampshade, a light sculpture that illuminates your room.

The re-edition of Rombo, made possible thanks to Alisée Matta, is produced in collaboration with Fonderia Artistica Flli Bonvicini, a historic company with which the artist had often worked.

Limited edition of 100 pieces, with engraved identification number and artist's signature. Each piece is accompanied by a Certificate of Authenticity.

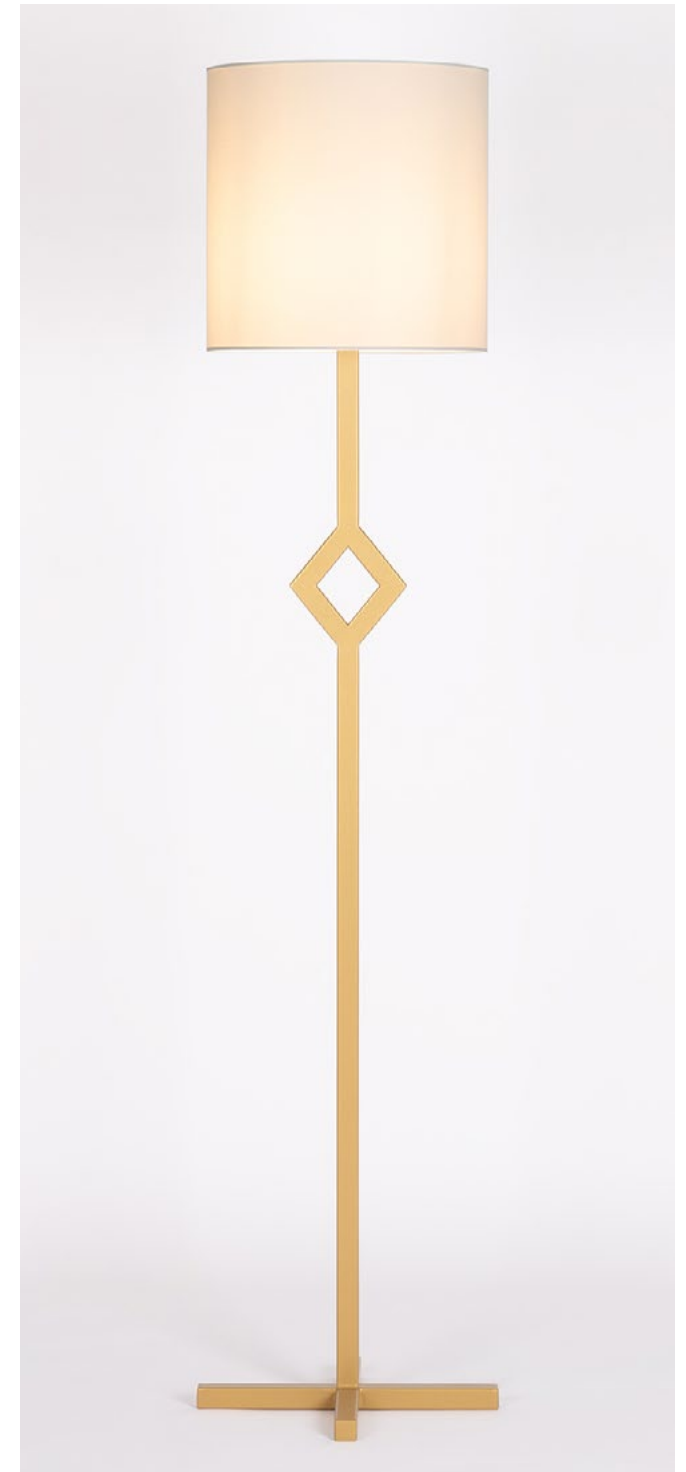
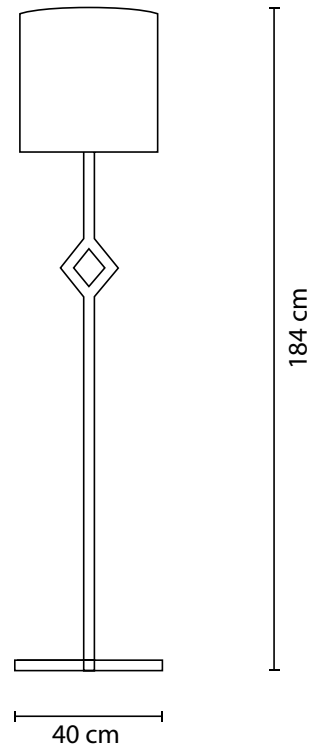

TOBIA SCARPA

(1935)



In his long professional activity Tobia Scarpa has been dealing with architecture, restoration, set-ups, industrial design, graphics, teaching. Since 1960s he established himself as a leader in industrial design.

Tobia Scarpa was born in 1935 in Venice, where he graduated in architecture (IUAV) in 1969. Curious designer, in his long professional activity he has been dealing with architecture, restoration, set-ups, industrial design, graphics, teaching.

Starting from the 1960s, he established himself as a leader in industrial design, through collaboration with Venini, Gavina, Flos, B&B and Cassina. For Dino Gavina he designed Pigreco chair (1960), Bastiano sofa (1960) and Vanessa bed (1962), pieces that later became iconic on the international design scene. Always alongside the Bolognese entrepreneur he took part in the creation of Flos, for which he designed numerous lamps including Fantasma (1961), Foglio (1966) and Biagio (1968). He then collaborated with various important Italian and international companies.

Numerous houses were built for different clients, new homes: Casa Lorenzin (1976), Daolio (1988), Meroni (1992); and restorations: Villa Fragiaco (1975), Casa Tonolo (1978), Casa Casas – Martinez (1989), Casa Montezemolo (1992), Casa Caccione (2005) and Casa Roversi (2007). Important restorations were carried out for public and private institutions: Palazzo del Monte in Reggio Emilia (1989), Loggia dei Cavalieri in Treviso (1990), Palazzi Brusati Bonasi in Carpi (1994), Museo del Mercato Vecchio in Verona (2000), and Gallerie dell'Accademia in Venice (2013) with the related set-up of the ground-floor rooms (2015-2019). Finally, we recall the recovery plan for the Certosa Island in Venice (2010). In 2020 Ca' Scarpa museum based on a project by Tobia Scarpa has been inaugurated inside a former church in Treviso.

Between 2001 and 2009 he devoted himself to teaching at the Universities of Venice and Alghero. He received several international awards, starting with Compasso d'Oro in 1969 for Soriana chair. In 2008 he was awarded the Compasso d'Oro for his achievements during his career. His works have been included in permanent collection of important museums, such as Libertà chair at Louvre in Paris; have been selected for temporary exhibitions by important institutions among which Triennale di Milano and Venice Biennale and have been subject of several monographic exhibitions in Italy and abroad and of a considerable number of publications in national and international magazines.

In 2020 Tobia Scarpa realizes for Paradisoterrestre three limited edition artworks, starting from an interpretation of Melencolia I, enigmatic masterpiece by Albrecht Dürer.

FESTUCA LAPIS

TOBIA SCARPA

2020



FESTUCA LAPIS

Designer:
Tobia Scarpa

Materials:
Carrara marble

Paradisoterrestre Edition
2020

Nr. 2 blocks
W 60 | D 30 | H 60 cm
W 23,6 | D 11,8 | H 23,6 in

An artistic project by the Venetian architect who, on the occasion of the exhibition Tobia Scarpa_ Dall'arte della misura silenziosamente (Paradisoterrestre Gallery – Bologna, 2020), creates three limited edition artworks for Paradisoterrestre, starting from an interpretation of Melencolia I, enigmatic masterpiece realized by Albrecht Dürer in 1514.

Tobia Scarpa breaks down the representation, extrapolating two of the key elements present in Dürer's engraving related to the geometric-mathematical field: the polyhedron and the magic square.

Festuca Lapis, a sculpture in Carrara marble, is the result of Tobia Scarpa's investigation on the mysterious Dürer's solid, a suggestion handed down from his father Carlo Scarpa.

The sculpture – a unique piece – is accompanied by a Certificate of Authenticity.

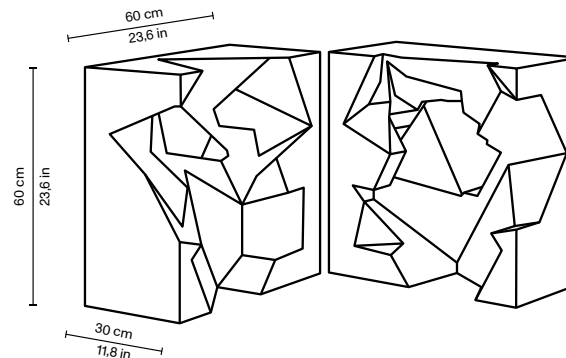

GEOMETRIE NASCOSTE

TOBIA SCARPA

2020



GEOMETRIE NASCOSTE

Designer:
Tobia Scarpa

Materials:
printing on Fabriano "Tiepolo"
paper 290gr, double glass
and aluminium frame

Paradisoterrestre Edition
2020

Print
L 56 | H 76 cm
W 22 | H 30 in

Frame
W 70 | H 90 cm
W 27,5 | H 35,4 in

An artistic project by the Venetian architect who, on the occasion of the exhibition Tobia Scarpa_ Dall'arte della misura silenziosamente (Paradisoterrestre Gallery – Bologna, 2020), creates three limited edition artworks for Paradisoterrestre, starting from an interpretation of Melencolia I, enigmatic masterpiece realized by Albrecht Dürer in 1514.

Tobia Scarpa breaks down the representation, extrapolating two of the key elements present in Dürer's engraving related to the geometric-mathematical field: the polyhedron and the magic square.

In Geometrie Nascoste – a limited edition of 100 prints, signed and numbered – the architect focuses on the magic square, researching and identifying symmetries in the numerical configurations of Dürer and Benjamin Franklin.

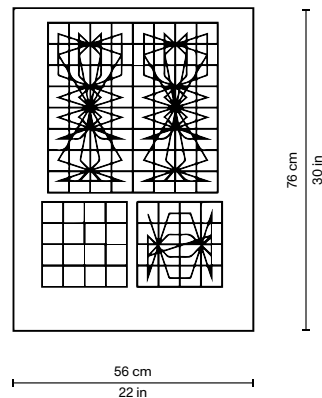
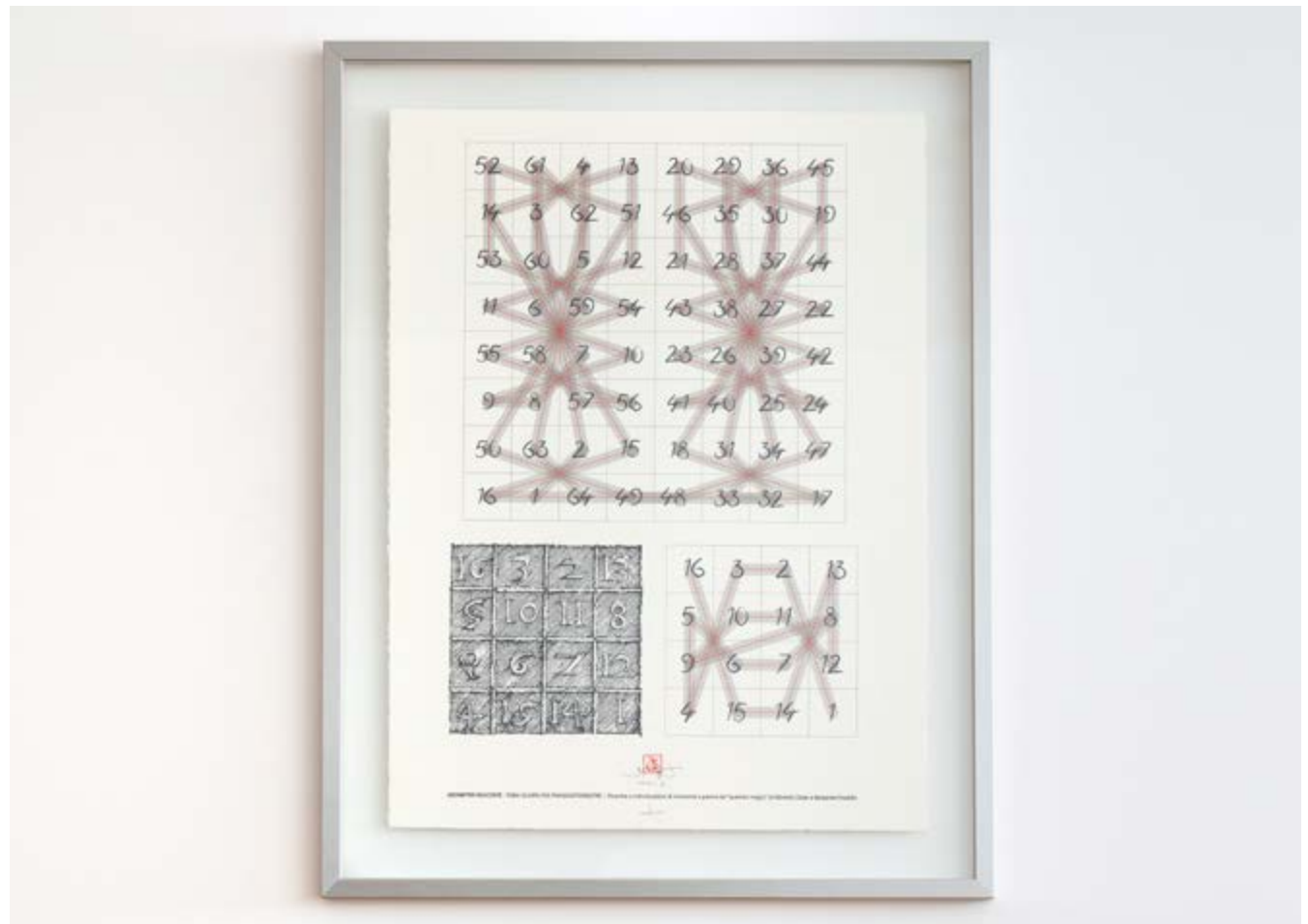

SCUDO MAGICO

TOBIA SCARPA

2020



SCUDO MAGICO

Designer:
Tobia Scarpa

Paradisoterrestre Edition
2020

Materials:
metal structure with brass
welds, circular base in
natural iron, brass sphere that
allows manual rotation
of the sculpture

W 28 | H 40 | Ø 23 cm
W 11 | H 15,7 | Ø 9 in

An artistic project by the Venetian architect who, on the occasion of the exhibition Tobia Scarpa_Dall'arte della misura silenziosamente (Paradisoterrestre Gallery – Bologna, 2020), creates three limited edition artworks for Paradisoterrestre, starting from an interpretation of Melencolia I, enigmatic masterpiece realized by Albrecht Dürer in 1514.

Tobia Scarpa breaks down the representation, extrapolating two of the key elements present in Dürer's engraving related to the geometric-mathematical field: the polyhedron and the magic square.

Scudo Magico, a sculpture in iron and brass, is the result of Tobia Scarpa's investigation on the mysterious Dürer's solid, a suggestion handed down from his father Carlo Scarpa.

The sculpture – a limited edition of 9 pieces – is accompanied by a Certificate of Authenticity.

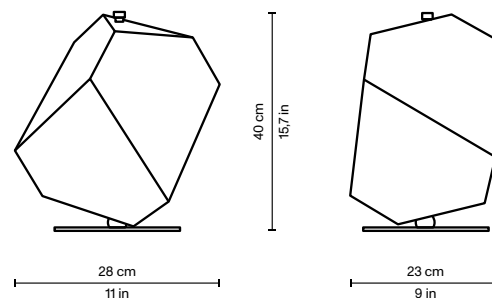

Photo credits:

Photographic archive:

Santi Caleca
Margherita Cecchini
Alba Deangelis
Bruno Elisei
Hugo Glendinning
Giovanni Gori
Stephan Julliard
Jill Kennington
Giorgio Liverani
Lorenzo Pennati
Oskar Proctor
Elena Rosignoli
Andrea Rossetti
Alessandro Saletta
Matthieu Salvaing
Casper Sejersen
Mattia Tonelli
Alberto Vendrame
Claudia Zalla

Paradisoterrestre

paradisoterrestre

© Paradisoterrestre 2026

Registered Office
Paradisoterrestre srl
Via I Maggio, 77
40064 Ozzano dell'Emilia (Bo) Italy
+39 051 03 53 291

info@paradisoterrestre.it

paradisoterrestre.it

[@paradisoterrestreofficial](https://www.instagram.com/paradisoterrestreofficial)